

# Above Grade

Coping with the Building Boom Bust



# Cafe Fresco Central Market now open!

Now @ three convenient locations  
Cafe Fresco Riverside  
Cafe Fresco BKK  
Cafe Fresco Central Market



- Smoothies
- Fresh Juice
- Coffee
- Antipasta
- Sandwiches
- Cakes
- Bakery
- Wines
- Salads
- Tea

Join the  
"Cafe Society"  
today...



Open Daily from 7 am - 6 pm

Cafe *Fresco*

Cafe Fresco  
#58 Street 53, Phnom Penh,  
(opposite Central Market)  
Call 023 214 984



chow

CHOW EIGHT  
10 am - 3 pm

Choose one from three categories plus choice  
of tiger draught, glass of chow red or white,  
coffee, tea or soft drink

Noodles, wok fried  
Noodles, in a broth  
From the garden

All for \$8

Along Sisowath Quay  
@ The Quay Hotel  
Tel: +855 23 224 894  
[www.chowcambodia.com](http://www.chowcambodia.com)

Family should be friends  
& friends should be family.

**TOP 10**  
Family & Friends



Introducing TOP 10 Family & Friends

**Only 5c/min to your top 10 hello numbers.**

Enjoy even more calls to your loved ones with TOP 10 Family & Friends. At only 5 cents per minute you can stay in touch more often than ever before. Register the ten **hello** numbers of your favourite people today and get closer to family & friends far away. Only with **hello**.

**To register:** • Dial 8363 and follow voice instruction or  
• Dial \*103# and follow screen instruction  
For more information, please call 1452.

It all starts  
with **hello**

## Editorial

“AFTER DECADES OF stagnation, Phnom Penh’s economy is vibrant once more, investors flocking to back the city’s rapid development ...” So we wrote back in September last year (AsiaLIFE Guide #21). Five months on and we - like most western leaders and major bankers - have egg on our faces. The construction boom has gone bust and the property market is in freefall.

This month, we return to the scene of our crime. Instead of asking whodunit? – after the list of suspects is without end – we ask, “what next?” Johan Smits speaks to a number of the country’s leading architects and designers to find out their vision for the future. The answer is, perhaps surprisingly, more reflective than knee-jerk.

We also take the opportunity to talk to two long-term Cambodian expats – Bill Grant and Darryl Collins – who in their own special ways have played a significant part in shaping the design of this country.

Elsewhere, the magazine has a distinctly romantic feel, in keeping with the glorious 14th. In Food, we give the low-down on the most

romantic places to spend that special day, while in Bar Stool we look at the best places to go if you want to have a lofty perch on that, or any other, day.

A big date to remember this month is Feb. 11. The night of AsiaLIFE Guide’s first Blind Date Game Show. Eight lucky men and women are participating in that good ol’ Dating Game/Blind Date game show at Talkin to a Stranger. This month also marks our first photo competition together with hello. See page 89 for details.

As always we look forward to receiving your comments on this issue, or any other aspect of life in the Penh. Keep on sending those emails to:

[asialifephnompenh@gmail.com](mailto:asialifephnompenh@gmail.com)

We hope you enjoy our 26th issue. 🇰🇹



Does your business need better exposure around town?

PHNOM PENH  
**AsiaLIFE** guide

Advertise, and put the spotlight on your business.

Contact us at: [asialifephnompenh@gmail.com](mailto:asialifephnompenh@gmail.com)

or 012 261 449

[www.AsiaLIFEGuide.com](http://www.AsiaLIFEGuide.com)

# contents

in the penh

calendar

storyboard

coverstory

food corner

40

scrapbook

bar stool

48

8

12

50

kaleidoscope

14

leisure & wellness

18

54

next generation

26

60

## Asian Bistro

A stylish and lively riverfront Bistro & Bar featuring contemporary Asian cuisine with a large tapas menu and popular 'Sizzler' grill platters with imported steak. An extensive selection of international wines, beer and single malts complements an afternoon-long happy hour. Sofas, free WIFI, air-con or outdoor terrace seating.

## Lounge

The upstairs Riverhouse Lounge balcony provides a panoramic view of the riverfront and the best cocktails in Phnom Penh. Popular nightclub with International DJs, music, dancing. Packed on weekends with a trendy crowd of young Khmers and local expats.

### Contact info

Address: Corner of St. # 110 & Sisowath Quay

Reservations: 012-299-161

### Email

Restaurant: [dine@riverhousecambodia.com](mailto:dine@riverhousecambodia.com)

Lounge: [party@lounge.riverhousecambodia.com](mailto:party@lounge.riverhousecambodia.com)

### Open hours

Restaurant: 10:30am-11:00pm

Lounge: 4:00pm-2:00am

**Weekends open until dawn**

  
riverhouse  
asian bistro & lounge

# PHNOM PENH AsiaLIFE guide

**Publisher & Editor-in-chief:** Mark Jackson  
mark@asialifeguide.com

**Managing Editor:** Naomi T. Robinson  
naomi@asialifeguide.com  
Tel: 012 261 449

**Associate Editor:** Johan Smits  
johan@asialifeguide.com

**Art Director:** Keith Kelly  
keith@asialifeguide.com

**Sales Manager:** Qudy Xu  
qudy@asialifeguide.com

**Sales:** Sorn Chantha  
chantha@asialifeguide.com

**Photographers:** Nathan Horton, Virginie Noel & Chean Long

**Accounts & Distribution:** Seang Seyha

Special thanks to: Our Books, Sam Campbell, Adam Fitzgerald, David Flack, Darren Gall, Craig Gerard, Trevor Keidan, Thomas Angus, Will Koenig, Gwang Ching Lee, Nora Lindstrom, Ried Sheftall, Sam Moffet, Andrew Nette, David Preece, Angela Savage, Uli Schmidt, Vuth, Laura Watson – for their contribution to this issue.

For advertising and marketing enquiries please call **Qudy** on 012 960 076.

If you want a copy of AsiaLIFE Guide Phnom Penh delivered to your doorstep email: [asialifephnompenh@gmail.com](mailto:asialifephnompenh@gmail.com)

AsiaLIFE Guide Phnom Penh is printed in Cambodia by Digital Advertising, 90 Street 44MC, Sangkat Stung Meanchey, Khan Meanchey, Phnom Penh, Tel: 023 987 600.

**On the Cover:**  
Cover photography and design by Keith Kelly. Artistic inspiration from Blek le Rat & Banksy.



AsiaLIFE is a registered trademark.  
No content may be reproduced in any form  
without prior authorisation of the owners.  
© Mekong Media Company Ltd.



shopping 62

business 67

getaways 72

map 74

unplugged

- 87
- 30 Restaurant Guide
- 31 Bargain Bucket
- 37 Recipe Corner
- 35 Review
- 43 Bar Guide
- 44 Bar Talk
- 46 Grapevine
- 51 Bootleg
- 52 Culture Guide
- 53 Arts Diary
- 55 Leisure & Wellness Guide
- 56 Beauty Spot
- 57 Sam Moffett
- 58 Nick Walsh
- 61 Next Gen Guide
- 64 Shopping Guide
- 68 Business Guide
- 69 Trevor Keidan
- 76 Getaway Guide
- 83 Letter from America
- 84 Challenge Nora
- 85 This Month in History
- 86 Horoscope
- 87 Best Kept Secret
- 90 Quiz
- 90 Sudoku

home is where The SHOP is  
- since 2001 -  
bakery and delicatessen # 39, street 240, Phnom Penh  
023 986 964 or [theshop.cambodia@gmail.com](mailto:theshop.cambodia@gmail.com) to place your orders

## The Month That Was

food, evictions, celebrations



■ **BISTRO ROMANO**  NagaWorld's newest restaurant addition, welcomed members of the press to its lavish opening last month. No need to gamble about which item on the menu to choose – all the dishes we tried were delicious, in particular the divine duck liver with caramelised figs. The Italian menu lists provincial specialties and recipes that are unique to different parts of Italy. Prepared by Italian chef Jacob Angerer and his team, all ingredients are handpicked for their quality and taste to bring out the distinctive flavour of each dish.

Inspired by the “Carnival of Venice,” the décor of Bistro Ro-

mano plunges you straight into a distinctive Italian atmosphere. Just don't get paranoid by the giant fat cherubs painted on the ceiling staring into your plate, or the countless pairs of eyes watching you eat from behind the Venetian masks on the wall.

Bistro Romana promises us several food festivals that will let us explore Italy's various regional cuisines, each with its unique ingredients and wines. If you're looking for a change, NagaWorld also offers Korean BBQ, Chinese, French and fusion food restaurants, as well as a cigar & wine bar, lounges, a spa and plenty other entertainment possibilities.

*Ground floor hotel wing of NagaWorld, Tel: 023 228 822*

■ **DEY KRAHOM EVICTIONS**

An estimated 90 families from the Day Krahom Community were forcibly evicted from their homes late last month. 300 workers backed by bulldozers and cranes cleared away the decade-old community. Some families have relocated to a site on the outskirts of the city that is lacking in both electricity and running water. Other families are being temporarily housed at the Bridges Across Boarders volunteer house and the Aziza School House. Donations of cash or food and

sanitation supplies (washing powder, soap, shampoo) as well as suitable second hand clothing has been requested. If you are interested in donating please contact Bridges Across Boarders at [info@babsea.org](mailto:info@babsea.org)

■ **YES THEY DID!** 

Late last month Democrats Abroad Cambodia hosted a party at the Gym Bar to mark the inauguration of America's 44th president, Barack Obama. Over 150 revellers were glued to the many TV screens eager to bid the Bush Administration farewell and welcome President Barack Obama along with a new era of hope and change. 

**Comme à la Maison**  
**Delicatessen**  
Restaurant, Deli Shop & Catering



13 St 57, Phnom Penh - 023 360 801 / 012 951 869  
[www.commealamaison-delicatessen.com](http://www.commealamaison-delicatessen.com)  
Open daily from 06:00 to 22:30



# News & Events

blind date, marriage, last friday, star-cell, execom



**■ BLIND DATE GAME SHOW**  
AsiaLIFE along with Talkin to a Stranger will be hosting the first ever Blind Date game show on Wednesday, Feb. 11. Just like the TV game show from days gone by a bachelorette will ask questions of three bachelors whom she cannot see. Based on the answers the men give she will choose one lucky man to join her on a dream

date. The whole process is then repeated with one bachelor and three bachelorettes. The entire debacle will be carried out in front of a full bar audience at Talkin to a stranger. The two winning couples will be awarded bottles of Champagne courtesy of Quarto Products and will enjoy their first dates together at Malis and Topaz. The remaining contestants will

also receive consolation prizes from Quarto Products. Prizes will also be given to members of the audience.

**■ JUST MARRIED! ⚭**  
After a year of collecting, the French Cultural Centre intends to exhibit over 1000 wedding photographs from France, Lithowania, China, Cambodia, and elsewhere.

The subject of the photographs some of which date back to the 19th century invite us into their intimate lives and into their heritage, sharing with us their memories. This exhibition of wedding portraits promises to transport viewers through the space and time of universal happiness. No body says 'happy Valentine's Day' like the French Cultural Cen-



85, Sothearos Blvd  
Tel: (023) 220 873  
www.ichingdecor.com  
ichingdecor@online.com.kh



tre. Just Married Opens Feb. 13 at 6.30pm.

**■ LAST FIRST FRIDAY**

The rumours are true. After years of dominating the Phnom Penh nightlife first Friday after first Friday, Elsewhere is saying Adieu. The last first Friday party will take place, you guessed it on Friday, Feb. 6. Where now will expats, backpackers, flashpackers and Khmers all come together once a month for a communal drunken dip in the pool? It's truly the end of an era.

**■ NEW PORT**

Because of an increasing demand for waterway transportation the government of Cambodia has announced a plan to begin construction on a new river port by the end of this year or early 2010. The port, estimated at \$25 million, will be constructed just south of the city in the lower Mekong River area not far from the existing Tonle Sap River port on northern Sisowath Quay. The facility will reportedly be six times larger than the current Phnom Penh port and have a capacity of 300,000 containers per day.

**■ STAR-CELL PROMOTION**

Star-Cell has launched its Star 300 promotion whereby everybody who uses a 098 SIM card can get 300 minutes free every month. The promotion runs till the end of March and is available to both new and current subscribers. Just dial \*800\*01# and Sopheap's your uncle.

**■ EZECOM UNITES WITH RED-LINE COMMUNICATIONS GROUP**

Redline, a provider of WiMAX and broadband wireless infrastructure products, announced that its RedMAX equipment has been chosen by Ezeecom, a Cambodian ISP, for its WiMAX network. "Redline's RedMAX products deliver the performance and features that we need to bring connectivity to our customers today," said Ezeecom's CEO explaining the reason behind their choice. It's reassuring to know that the RedMAX 4C operates in the 2.5 GHz and 3.5 GHz spectrum bands and includes a modular, standardised µTCA chassis base station that is small and lightweight. 

# Valentine's Day Events February 14th



**■ RAFFLES HOTEL LE**

**ROYAL ~ FALL IN LOVE OVER CANDLELIGHT AND DINNER**  
Valentine's Dinner Menu at Restaurant Le Royal

A crisp glass of Champagne followed by four courses of Chef Gerald Reichstein's gourmet food, designed to make you fall deeper in love. Price US\$55 per person

*For Reservations please call 023 981 888 Ext. 1442  
Or email: Dining.leroyal@raffles.com*

**■ BISTRO ROMANO ~ A NIGHT OF ROMANCE, DINNER AND WINE.**

An Italian Inspired five course Valentine Dinner for two accompanied with wine and champagne and a free flow of Lamura, Grillo di Sicilia, 2006. Price US\$110 per couple

*For Reservations please call 023 228 822  
Dinner is served from 7pm to 10pm.*

**■ WINKING FROG**

Free Cocktails for women and live music.  
*8pm till late.*

**■ PONTOON ~ ILLEST HEART VALENTINE'S BASH**

DJ Illest rocks the boat. Drink specials.  
*9pm till late *

**■ TALKIN TO A STRANGER ~ MY FUNKY VALENTINE**

Latin Sandwich goes romantic. Salsa, Merengue, Samba, Latin funk and great dance music to get you all juicy.

*Kicks off at 9pm*

**rather** not think about it?



**When it comes to retirement planning many of us are guilty of putting it off until tomorrow.**

Put off by the thought of inflexible pension plans? Don't want to tie up large sums of money for the long term?

Most retirement plans today offer the flexibility and access you need to cope with life's changing circumstances.

At Infinity, we're here to help you find the best retirement solution so that your future is secured without any hassles and headache.

[www.infinsolutions.com](http://www.infinsolutions.com)

An associate of Infinity General Insurance 

# Bangkok Contemporary Art Scene

THE BANGKOK ART AND CULTURE CENTER (BACC) is still showing its second major exhibition 'Krungthep 226. Art of Yesterday – Image of Tomorrow' until Feb. 15. The visual art exhibition traces the life of Bangkok (called "Krungthep" by Thais) from the beginning 226 years ago through the present via the works of over 90 artists, photographers, architects and filmmakers.

Divided into four zones the exhibition occupies two floors of the gallery space. One of the zones, Dream Bangkok, presents an investigation of how Thai and international artists see Bangkok both now and in the future. Works anticipate future catastrophes, whether flooding, terrorism, political unrest, water and air pollution, as well as collapsing community life resulting from the new urban city planning and development. Some of the works propose an alternative cityscape free from overcrowding advertising billboards, while others offer a more fanciful imagination of Bangkok's future, such as envisioning the return to nature.

While less extensive in scope than the previous show, 'Traces of Siamese Smile,' it still shouldn't be missed if you have a couple of hours to spare in between shopping at MBK or Paragon. The show offers an apocalyptic vision of these malls that might look appealing, depending on how much you love or hate shopping.

Bangkok Art and Culture Centre, 939 Rama I Road, Bangkok (opposite MBK shopping center). BTS station: 'National Stadium'. Tel. 02 214 6630-1. Opening hours: Tue – Sun 10am – 9pm, free admission. [www.bac.or.th](http://www.bac.or.th)



**The Coffee Makers**  
ALL THE BEST WE SERVE

@ coffee  
@ food  
@ and much more

Lose yourself in the taste!

50 Sihanouk Boulevard, Chamkarmorn ☎ 023 987 721 ☎ [porsithear@gmail.com](mailto:porsithear@gmail.com)

# Openings

clubs, pizza, baked



## ■ FLY LOUNGE

Fly Lounge on Street 148, a few doors down from Metro, had its soft launch early last month. The unique venue, which includes an indoor swimming pool, is a welcome and curious addition to the Phnom Penh bar scene. Featuring a bar, a Middle Eastern-style lounge, a dance floor and a mezzanine, the surprisingly large establishment has already attracted an upbeat mix of Khmer and expat patrons to enjoy cheap and well-mixed cocktails. The menu includes late night snacks and nibbles, and a wine list will be added soon. The Fly Lounge promises its patrons some interesting tunes. The pool, which might attract goldfish lovers as one side is made of glass, is planned to be finished early this month after which a grand opening will follow. Open 5pm to 12am on weekdays, and until 2am on weekends.

*Fly Lounge, 21 Street 148 Tel: 089 509 007 / 016 744 110  
www.flyloungecambodia.com*

## ■ MEA CULPA

Long-time pizza enthusiast Ben has opened a hot new restaurant in Kampot serving up the best pizzas south of the Tonle Sap. Pizzas are thin crust and served straight out of the home-built wood-fired oven. His freshly made creations range from US\$6 – US\$9 but Ben has other items on his menu including imported steak and generous portions of healthy salads. The guesthouse's

spacious rooms are equally great value for money and range from US\$18 to US\$25. In the unlikely event that you would feel bored in charming Kampot, check out Ben's excellent collection of DVDs and books that may persuade you to stay on for an extra day. Despite his father's wish for him to choose "a real profession," Ben has created a great addition to Kampot's growing guesthouse scene. Mea culpa, dad...

*Mea Culpa, Located near the lotus pond, Tel: 012 504 769*

## ■ MADELEINE'S CAFÉ & BAKERY

This recently-opened restaurant and bakery is offering a variety of baked goods, organic lunches and catering services. Fresh fruit shakes come at US\$2 and tea and coffee at US\$1. Cake and bread can be ordered and the lunch menu is mostly vegetarian. Catering and dinner parties can be organised for you at your own home.

*Madeleine's Café & Bakery, 19 Street 228, Tel: 012 988 432  
cookadom@hotmail.com*

## ■ GASOLINA CLUB

Gasolina has opened a new bar-discotheque located inside its spacious garden. The indoor space, that includes its own bar, can be rented out for private parties. Special events happen on Fridays, movies on Sundays, and happy hour from 6 to 8pm.

*Gasolina, 56-58 Street 57, Tel: 092 273 949 www.club-pp.blogspot.com*

Riverside, #21 AEo, St. 148, Phnom Penh, Cambodia  
www.flyloungecambodia.com

# calendar

## February

quizzes, cupids, and carnival

### sunday

**01**  
Pontoon - One Drop Sundays

**Salsa Sundays**

Dance at the rooftop FCC Phnom Penh every Sunday from 5.30pm

**Sunday Brunch**

Free-flowing Moët & Chandon Champagne every Sunday from 11:30am to 3pm at the InterContinental Hotel

### monday

**02**

**Revolution Poker Night**

GLBT encouraged

**Vespa Malt Monday**

Four single malts for only US\$15 at the Green Vespa

### tuesday

**03**

**Mark Pollack**

Opening at Meta House 6:00pm

**Gym Bar Quiz**

**Alley Cat Rib Night**

Full-rack for US\$8, half-rack US\$5.50 at Alley Cat Café, every Tuesday

### wednesday

**04**

**Vespa Wine Wednesday**

Buy one bottle of wine and get another for free at the Green Vespa

**La Croisette Live Music**

live music -Every Wednesday

### thursday

**05**

**Glory Hole Gay Night with Cabaret Dancers - Pontoon**

**Talkin to a Stranger**

Lamb dinner - Thursdays - \*booking essential

**08**

**One Drop Sundays**

Reggae Dub and Ska BBQ and US\$2.50 Mojitos at Pontoon

**Sunday Brunch**

Salsa Sundays

**09**



**Meak Bochea Day**

**Revolution Poker Night**

Vespa Malt Monday

**10**

**Talkin Head Trivia**

Pit your brains against the Quiz-Master at Talkin to a Strange

**Gym Bar Quiz**

Alley Cat Rib Night

**11**

**Blind Date Game Show at Talkin to a Stranger**

Blast from the past dating game. See Ad on page 42

**Australian Women's Connection (AWC) Lunch**

Second Wednesday each month. For info call 012 223 801

**Vespa Wine Wednesday**

La Croisette Live Music

**12**

**Glory Hole Gay Night with Cabaret Dancers - Pontoon**

**Patchwork Art Work**

Opening for Maggie Bol and Lenny Bart at Gasolina 7:00pm

Talkin Lamb Dinner \*

**15**

**Pontoon - One Drop Sundays**

**African Documentaries** at Meta House

Salsa Sundays

Sunday Brunch

**16**

**Faces of Asia at the Centre for Friends**

Siem Reap

**Revolution Poker Night**

Vespa Malt Monday

**17**

**Kampuchea Death and Rebirth at Meta House**

**Alley Cat Rib Night**

**Gym Bar Quiz**

Test your knowledge against Randal at the Gym Bar every Tuesday night from 9pm - US\$30 bar tab for the winners

**18**

**Vespa Wine Wednesday**

La Croisette Live Music

**19**

**Glory Hole Gay Night with Cabaret Dancers - Pontoon**

Talkin Lamb Dinner \*

**22**

**Pontoon - One Drop Sundays**

Salsa Sundays

Sunday Brunch

**23**

**Revolution Poker Night**

Vespa Malt Monday

**24**

**Mardi Gras**

**Tim Page**

Opening at Meta House

**Carnival at Gym Bar**

Mardi Gras maddness & celebration of Carnival. Quiz, Contests and more. Watch for details.

**Talkin Head Trivia**

Alley Cat Rib Night

**25**



**Vespa Wine Wednesday**

La Croisette Live Music

**26**

**Glory Hole Gay Night with Cabaret Dancers - Pontoon**

Talkin Lamb Dinner \*

**01**

**Pontoon - One Drop Sundays**

Salsa Sundays

Sunday Brunch

**02**

**Revolution Poker Night**

Vespa Malt Monday

**03**

**Gym Bar Quiz**

Alley Cat Rib Night

**04**

**Vespa Wine Wednesday**

La Croisette Live Music

**05**

**Glory Hole Gay Night with Cabaret Dancers - Pontoon**

Talkin Lamb Dinner \*



IT'S NOT JUST ABOUT SPEED

Surf more, talk more at home with Go Online Bronze package, because you deserve more than just speed!



\$49 per month Unlimited Internet\*

DSL 256kbps

Half speed during peak hours @ 300MB allowance

\*7pm to 7am Monday to Friday, Saturday 12pm to Monday 7am

VoIP

- No data charge for ONLINE VoIP calls
Receive incoming Domestic/International Calls
\$3 rental/month per 084xxxxxx access number inclusive of unlimited calls to 084, 013, and 083 networks
10¢/minute between 084 and other networks
The cheapest outgoing international call rates



See leaflet for more details or contact our Call Center \*Conditions apply

friday

Disco Pugwash 80's Boat Cruise by Primitive Souls and Talkin to a Stranger 8pm

First (and Last) Friday at Elsewhere

Little Things Opening at Equinox 7:00pm

Alley Cat Friday Devious Dice

The Hellhounds at Velkommen Inn

Winking Frog Live Band

saturday

Launch of the 'Twist it Up' Hip Hop Parties at Pontoon. Hosted by Hydro, Tech 12 and DJ Illest. Performance by Tiny Toones!

Winking Frog Live Band & Karaoke

Soundz of Berlin DJ Derek Risle aka Der E-Kreisel from Berlin plays La Croisette

Live Music at Revolution

Metahouse Opening - Raining at Preah Vihear

12

Tribute to Svay Ken Opening at Java 6:00pm

Just Married Opening at CCF 6:30pm

The Hellhounds at Velkommen Inn

Winking Frog Live Band

Alley Cat Friday Devious Dice

14

Valentine's Day For Events See Page 9

Twist it Up Party' Hip Hop Night at Pontoon

Live Music at Revolution

Winking Frog Live band & Karaoke at Winking Frog every Saturday night from 8:00pm till late

20

Ministry of Sound Bert Bevans is back at Pontoon. (Bring a life vest)

Winking Frog Live Band every Friday night from 8:00pm till late

Wine Tasting at Saffron US\$13

Party at Rubies Wine Bar

The Hellhounds at Velkommen Inn

Alley Cat Friday Devious Dice US\$1 roll wins drinks and prizes at the Alley Cat Café

21

Live Music at Revolution

Twist it Up Party' Hip Hop Night at Pontoon

Malaysian Theatre at Art Café

Winking Frog Live Band & Karaoke

27

Velkommen Inn The Hellhounds play live every Friday from 8:00pm

Winking Frog Live Band

Alley Cat Friday Devious Dice

28

Khachao Touch Opening at Art Café

Twist it Up Party' Hip Hop Night at Pontoon

Live Music at Revolution

Winking Frog Live Band & Karaoke

06

Winking Frog Live Band Alley Cat Friday Devious Dice

07

Twist it Up Party' Hip Hop Night at Pontoon

Live Music at Revolution

Winking Frog Live Band & Karaoke



CALL CENTER 013 72 72 72 023 72 72 72

Phnom Penh Head Office 60 Monivong Boulevard, Phnom Penh, Cambodia
Siem Reap Office #8-9, Mondul 2 Village, Svay Dangcum Commune, Siem Reap
Sihanouk Ville Office Group 1, Village 4, Sangkat 4, Mittapheap, Sihanouk Ville



# storyboard

## Streetsmart: Northern Riverfront

The riverfront north of Street 108 has two different faces. During the day, it caters to travellers entering and leaving Phnom Penh, while at night there's clubbing, pubbing and classy drinking to be had in some of the capital's most unique venues. Words by Nora Lindstrom.



Green Vespa

### ■ BEFORE SUNSET

Mekong Express bus terminal (corner of Street 102) and the passenger port located almost opposite set the tone for the strip immediately north of Street 108. Most of the bars, restaurants and cafés here open early to provide breakfast and lunches to travellers heading up to Siem Reap or catching the boat to Chau Doc.

Newly-opened restaurant Jaan, meaning 'plate' in Khmer, serves western-style breakfasts (US\$3-US\$6) from 7am at the corner of Street 106. A bit further up, little Chao Jome beats Jaan by an hour, opening at 6am with western and Khmer breakfasts as well as other food in the US\$4 range. If you find yourself without reading material for your long bus trip, Chao Jome also has a decent selection of used books (US\$4-US\$5), as well as a random assortment of toiletries and such.

A few doors up, the Green Vespa does not start serving until 8am, but has easily the most impressive fare. Try a Full Monty (US\$9) – all you can wish for from an English breakfast – or the signature brunch (US\$8), featuring smoked Norwegian salmon and Bloody Mary. These are worth coming for even if you aren't travelling out of town.

The Woolly Rhino bar and guesthouse is located just past the bus terminal. The bar serves drinks only, but there are 13 decently priced rooms (US\$7-US\$20) if you are making a quick splash and dash in town.

Mekong Express operates 'limousine' buses to Siem Reap four times daily from 7.30am. Tickets cost US\$11 one-way and can be purchased at the terminal, as well as travel agencies around town. There are several agencies in the immediate vicinity of the station that can sort out tickets for onward travel as well as visas to neighbouring countries.

Boats from the Passenger Boat Port go to Siem Reap and Chau Doc. Compared to the bus they are expensive – the four-hour journey to Chau Doc costs US\$22 one-way, while the five-and-a-half-hour journey to Siem Reap is a steep US\$35 for a single journey (three and half times the bus) – but for many first-time traveller, the river views are worth it. Boats for Chau Doc leave at noon daily, while boats for Siem Reap leave at 7.30am, also daily.

### ■ BEFORE SUNRISE

During the weekend, Phnom Penh's one and only Night Market kicks off between streets 108 and 106. Open Fridays to Sundays from 4pm to midnight, the market attracts many local shoppers, although it features a surprisingly boring selection of clothing, souvenirs and general tack. More exciting are the food stands at the back, where there are also mats for enjoying a sit-down dinner in true Khmer style.

Opposite the market is Phnom Penh party-goers' favourite floating bar, Pontoon Lounge. With added buoyancy since sinking last year, this place has seen a real face-lift in recent months. Visiting international DJs and MCs, as well as themed nights, including ladies' night on Wednesdays and gay night on Thursdays, all draw crowds to this unique venue on the Tonle Sap. The sofas on the main float are great for general chilling, while the boat offers some breezy respite from loud music during big nights. Open 6pm to 2am (Friday and Saturday to 4am).

Further along the river, there are a few Khmer restaurants overlooking the water. The flashiest of these is Bopha Phnom Penh. This massive restaurant is slightly over-the-top

in its Khmer-style decor, but by seating yourself on the balcony you can focus on looking at the river and leaving all the glitz behind. The menu is large and varied, with most plates costing US\$7 and up. Apsara dances are performed every night between 7.30pm and 9pm.

Across the street Jaan's menu features a mix of western and Khmer food at reasonable prices around US\$4-US\$5. The owners, whose other venues include Flavours and Liquid on Street 278, have made sure Jaan offers good happy hour deals, such as Angkor draught at US\$0.75 and cocktails for US\$2.50 daily between 4.30pm and 7.30pm.

The Green Vespa also offers grub beyond the morning. Check out the specials menu at this Irish/British pub, or simply pull up a pew at the bar and let Alan keep your glass filled. The Vespa also runs themed nights – on Malt Mondays, customers can try four single malts for US\$15, on Tuesdays any bottle of wine comes with complimentary cheese, while Curry Fridays offer curry and two local beers for US\$8.80. Open 8am to around midnight.

Further north, as the port ruins the view of the river, there is a Fairground with a small selection of children's rides as well as games. Rides cost between 1,000 to 5,000 riel, while games such as throwing darts at balloons costing 1,000 riel for seven darts. As staff speak very limited English there is no knowing how many balloons you need to hit to win. But with amazing prices including household cleaning items, notebooks, and the more traditional teddy bears, you might as well keep trying. Open from around 4pm to 9/10pm.

The very last worthwhile stop on this stretch is newly-opened China House. This beautifully restored colonial building hosts exhibitions on the ground floor, while the delectable lounge and bar on the first floor serves drinks and nibbles. The exposed wooden and tiled floors, demure colours, big sofas and the bar's high ceiling make the China House a fantastic venue. Add to that a buy-one-get-one-free happy hour between 6pm-8pm, and you might never want to leave. Open 6pm to around midnight, it's closed Tuesdays. 🇰🇷



Pontoon Lounge



Night Market



China House

# Phnom Penh Life: The Constant Gardener

Few are better qualified than **Bill Grant** to talk about the changing face of Phnom Penh. **Johan Smits** talks to the Scottish designer and landscape gardener who first settled in Phnom Penh in 1991.



**In his element**

THE MOMENT YOU WALK through the gate of his villa, Eddie the Blade is watching your every gesture from behind his employer's stretched 1960s Mercedes. One wrong move and Eddie will go for you. No, this is not London's East End – but Scottish designer Bill Grant's home in Toul Kok.

"He's bitten me twice," Bill says lovingly about Eddie, one of his five rescued dogs. "He's

got a bad leg, he's really spoiled and he's the alpha male of the pack, but I'm the supreme male, you know." After these reassuring words we start talking about how a self-confessed "Scottish country lad" ended up as one of Cambodia's most respected landscape designers.

#### ■ PRE-UNTAC DAYS

"What brought me here was an English friend who bought

a house behind the Le Royal," he explains. "She said, 'Bill I've got this fantastic house, I want to build a restaurant.'" That was in 1991 before the UNTAC period. Bill not only designed the interior for his friend's restaurant but also created the garden in front of it. The place was an immediate success with the UNTAC crowd when they arrived in Cambodia.

"The head of the U.N. mission used to come every day to the restaurant to eat and he liked the garden, so when he moved into his villa, he asked me to come and do his garden too," says Bill. Soon the Australian ambassador's residence followed suit, then the French embassy, and the American ambassador's residence. "I became the instant flavour of the month," he recalls.



I quite like the unstructured side of things, I feel unfettered and free here

#### ■ MAKING THE MOST OF THINGS

But Bill's design activities are not limited to gardens.

"My background is in fashion design in the 70s in London, with a Japanese partner," he says. "We were quite successful actually." Adopting an appropriately down-to-earth manner for a landscape gardener, Bill thinks he was just lucky to be born with good taste and the ability to use it.

"I can make the most of that particular talent, and it doesn't really matter to me whether it is fashion or interior or landscape, you know," he explains. To him it always comes down to the same thing – colours, textures, putting things together. Despite loving the fashion business, he's glad he's out of the very stressful environment that comes with it.

"I really enjoy what I'm doing now, although when the hot season comes, I'd rather be doing interiors – it's too hot outside," he says about his landscape work in Cambodia.

#### ■ TROPICAL EXPERT

When Bill first came to Asia he spent one year in Indonesia in 1979. Then he lived for three-and-a-half years in Tokyo but an acute attack of what he calls "Broken Heart Syndrome" led him to move to Thailand.

"I must say, of all the places I've lived, this is the one I loved the most," he says of Cambodia where he has been now for no less than 17 years. "I quite like the unstructured side of things, I feel unfettered and free here. Also, I've been dealing with the same people for years now, there's a big trust between us."

The first two people he took on were a cyclo driver and his son. They helped him put together the garden for the restaurant project back in 1991 and have been with him ever since. Now he has some thirty people working for him.

"It's very much like a family because they have been with me for so long," he says.

That length of time has also made him an expert in tropical plants. He still does the main-

tenance of the French embassy, one of his first projects, which has allowed him to learn what happens with certain plants over a fifteen-year period.

"Now when I do someone's garden, I know what it will look like in two years, five years, ten years," he explains. "I have my trusted plants. I know which ones do well, are easy to maintain and look good all year round, so I tend to go with those rather than experimenting with new things coming in from Dalat [Vietnam] that might be good for six weeks and then die." Calling Phnom Penh a somehow harsh environment for plants, Bill now tries to create an instant garden, which will just grow better and better.

It certainly has proved a successful approach. He has a mix of different projects including a big hospital in Kampot, an academy just outside of Siem Reap, hotels, a school, restaurants and private homes. "I quite like doing more modern buildings now because then you can get a more modernistic approach to the planting," he explains. "But you know, it's whatever the space demands, it's the character of the architecture."

#### ■ CHILD OF THE 60s

While talking we are interrupted twice with phone calls from people asking for instructions or trying to arrange things. His schedule seems to overflow but his calm demeanour betrays no sign of pressure. He clearly enjoys his work.

"I feel really rooted here," perhaps the pun is intended. "I'm living in a 60s house, driving my 60s Mercedes cars – being in my sixth decennium, it's all a matching set," he laughs. When asked why he needs two Mercedes, the response is characteristically deadpan. "The stretched one is to take the dogs out to the beach."

Loving old houses, Bill thinks Phnom Penh was the most beautiful city he'd ever known when he first came here. "Sadly, I've seen it systematically sort of destroyed," he says. "I'm not so very happy with what is happening to this city."

But some things are definitely an improvement to him. "I must say it's nice to go to Lucky and have an assortment of cheese." He recalls with a certain nostalgia the time when there were no shops, only five restaurants in the city and black-outs all the time. "It's still wonderful though," he smiles. ■

KNAI BANG CHATT  
the essence of Kep



Investing in love, caring and health has always been profitable. Come over and stay one more night. Invite your friends and spend unique moments at our beach resort and our newly opened Sailing Club.

**Book 2 Nights or 2 Rooms at Low Season Prices**

*This promotion is valid until September 2009.*

**Saturday February 14 – Valentine's night for lovers**

Candle light dinner at the Sailing Club. Book your table in advance.

info@knaibangchatt.com

www.knaibangchatt.com

Tel./fax: 023-212194

Cell: 017-917452 / 012-34974

# Boom and...a time for reflection

Over the past few years, construction in Cambodia has known an unprecedented growth. As the global economy goes into meltdown, the Cambodian volcano seems to have cooled off. Bad news for the country's architects and designers? Not necessarily. We spoke to a number of professionals about their activities in Cambodia and what they think the future holds. Words by **Johan Smits**.

"IT'S A GOOD TIME FOR restructuring and rethinking," says Bernard Wouters, architect and senior design manager at Archetype, one of Cambodia's largest architectural design firms. "I hope that people now have more time to think things through, for example by taking ecology more into account and adopting a more gradual

approach. Because of the economic slowdown it's not just playing catch up any more like it has been so far."

Bernard came to Cambodia in 1998 as a U.N. volunteer and also worked here on his PhD about Sensitive Heritage Planning. "Before I was active as an architect for some years in Europe but I really started my

career here," says the 39 year-old Dutchman.

Working in Cambodia, with its rich culture of handicrafts and cheap labour, has its advantages.

"It allows us to do lots of special, custom-design features," he says. "Here I'm not afraid of taking on labour-intensive projects which would be much more costly in Europe."

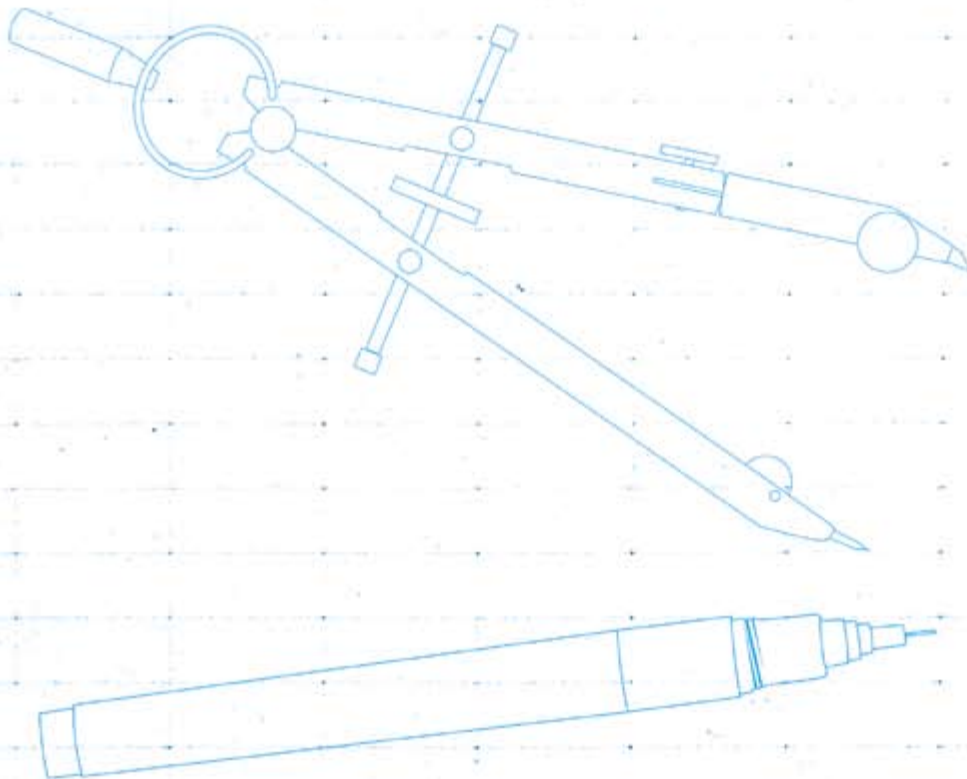





Rainer on the job at Formconsult

**Faults and defects on site are common and will be accepted by the client without complaints – a difficult basis for quality conscious architects and designers.**

To Pascal Banner, architect and builder at the company Architecture in Asia, it's also about easy access to people.

"We have more time to spend with staff," he explains. "You are closer to everything, the access to important people is easier," he says. But there is a flipside. "Dealing with money here is different, the administration is not the same," he says. "It's not like expats who are sent here by a company – we have to handle all this by ourselves."

Pascal's first visit to Cambodia was in 1992 when he was still studying at the University of Montpellier in his native France. His teacher was helping to restart the Royal University of Fine Arts (RUFA) in Phnom Penh and later Pascal assisted him with the renovation of the ITC, the Institute of Technology of Cambodia.

Like Bernard, he believes that the current economic slowdown has a good sense. "It offers a quiet time for us to study things."

He is also quite confident about the future. "Cambodia is going up which is good," he

says. "It has a positive effect on the real price of things here. If you charge a fee for a project to a person in Europe, he accepts it. If you charge that fee for the same project to the same person here, he thinks it's too expensive. They expect things to be cheap because they're in a developing country, but that's false."

#### ■ COST OR QUALITY?

Rainer Striffler established his company Formconsult in 2006. The German architect now employs three young Cambodian architects. According to him, getting established here can be difficult.

"The main designer in this country is still the profit-orientated construction company, and for clients price is still more important than quality," Rainer says. "Faults and defects on site are common and will be accepted by the client without complaints – a difficult basis for quality conscious architects and designers."

Khuy Py, head architect with Five-Arc, takes the contrasting viewpoint. According to him, sometimes foreign architects want everything to be to a perfection that can be expensive.

"They often use technology and materials that cannot be found here and have to be imported which adds a lot to the price," he says.

Py graduated as an architect at RUFA in 1999 and established Five-Arc in 2003. He thinks that local architects have an easier understanding of what Cambodian clients expect.

He is currently working on his biggest project 'Mount Dream Village', a 70-hectare weekend resort for tourists in Mondulki.

"It's a work in progress, designed around natural resources such as natural air flow instead of air-conditioning, the use of solar energy and wind power, and the creation of energy through a water dam," Py explains.

Rainer feels the perception of architecture and design in Cambodia is slowly changing. "There are a lot of Khmers who lived abroad and have been exposed to western standards and designs," he says.

#### ■ DESIGNING THE FUTURE

It's a view echoed by Swedish designers Sara and Frida Hulten who recently established The Room Design Studio. They offer home decoration, graphic and interior design, and architectural services.

"One challenge is tackling the Cambodian way of looking at the property of their neighbour and then copying it," says Sara. "But this is changing now. Before, for some reason, nobody wanted to stand out too much. That is not the case any longer."

According to her sister Frida, having a modern European-style home is becoming more important for Khmers. "For example, traditionally the kitchen was always separated from the main room," she says. "It was the space of the wife and had to be separate. Not any longer – it becomes one space."

This changing perception of architecture and design is still a long way off from how most professionals would like to see it.

"Here an architect is often seen as someone who makes a couple of drawings in one day, and there it ends," says Rainer. "It will take more time until society discovers the value of architec-



Room Design Studio is here, throw out that IKEA catalog



Songtry Tai - The man behind EK Design

ture and design with its huge influence on our daily life and even commercial success.”

■ **CREATING A NEW LANDSCAPE**

This perceived lack of understanding and appreciation is also experienced by Sarunya Lormaneenopparat, landscape architect and director of Sa.La.Design, which she established in 2007.

“They often think that I’m a gardener,” she says. “But large projects need someone who can make a real plan, a landscape architect with a real concept of a garden.”

Sarunya has worked on private projects such as the Frangipani Hotel in Phnom Penh as well as large mega-projects like Camko City.

“In Thailand people understand concepts easier,” she says about her native country. “Here it’s harder to understand what I do. It’s not only about beauty but also about function and ecology.”

Pascal makes a similar observation about Cambodian architectural students. Growing up in a different environment has shaped a mindset at variance to that commonly found in the West, according to him.

“It fundamentally affects your way of thinking,” he says. Not that Cambodian students are without skills.

“On the other hand they’re very good technicians, very good with computer design and 3D, it helps them a lot in concepts and there are some guys now with good ideas out there.”

■ **OPENING MINDS**

For Stephane Dawant, director of architecture at the interior design company I Ching, the main challenge is to open the minds of people. He hopes to achieve this through design.

“It’s important to me to train people to be creative,” he says. “Ideally I would like to open a school here,” the Belgian says. Stephane now has three Cambodian designers who usually work on their own.

Bronwyn Blue used to work with I Ching and opened her own company Beyond Interiors in October last year. The outgoing Australian doesn’t think that the appreciation of design is a cultural thing.

“It’s emotional,” she says. “It’s walking into this showroom and feeling good about what

**Before, for some reason, nobody wanted to stand out too much. That is not the case any longer.**

you see.” Bronwyn thinks that the understanding and appreciation of design is fundamental to the growth of the design sector in Cambodia. “There’s one thing to say ‘here’s the finished product’, and it’s another thing to value the thought process behind it.”

Like Stephane, she thinks that education needs to be improved.

“There’s more focus on the practical output of specific materials here, but there’s not a lot of fusing, cross-platform training, for example taking a particular material out of its usual function and think, ‘now how can this be used in a different way, for a different purpose?’” She would encourage anyone who has good ideas – exhibitions, demonstrations, projects etc. – to get in touch with her.



**Khuy Py, head architect with Five-Arc**

■ **CHANGING PERCEPTIONS**

Education needs improvement not only in design but also in the field of architecture, according to Bernard Wouters.

“Before the war there were a good handful of people but they all studied abroad,” he says. “A good project needs a good patron,” he points out. “Vann Molyvann had a good patron with the King – there was coherence and vision. Today every client fends for himself, protecting his own interests, highlighting his own project without regard for anyone else.”

However, Bernard says he sees a group of young architects who are willing to learn about the great masters from before the war. “But again, they need a good patron,” he repeats.

To Rainer, these pre-war masters should also have taken on the responsibility of passing on their knowledge to the new generation through teaching. “Moreover, today’s students have a profound lack of educational

resources, such as access to affordable good books and professional magazines,” he says.

One person who is doing his part in trying to change things is Songtry Tai from EKDESIGN, which offers architectural design and interior decoration services. The moment you walk into their funky office on Street 130, it’s easy to see how Cambodian design could be going through a revival. The reception area has more the feel of a contemporary art gallery than an office. The meeting room doubles up as an informal library where students can come and consult stacks of architecture books and fashionable design magazines, free of charge. Like Py from Five-Arc, Songtry was educated at RUFA. Nearly 90 percent of his clients are Cambodian, but he also has had some foreign-funded projects, most noticeably the private residence of the U.S. ambassador.

“The state of architecture in Cambodia is very much influenced by the political and economic situation,” he says. “Clients want to spend less money and think only about the business, about profit. Fortunately some clients don’t worry about money and want a good quality building.” According to him, business-people are starting to realise that a well-designed building attracts more customers.

“Private people too are increasingly becoming aware of this,” he says. “When they don’t use an architect, they often have to change things afterwards, break out walls, tear things down... Now they start to realise they can actually save money with an architect.”

■ **MORE TALK AND LESS ACTION**

But it’s not only using an architect that increases your chance of success. There has to be a good dialogue between the architect, the interior designer and the decorator. In



**Singapore kitchen**  
Singapore charcoal steamboat



Come experience the flavours of the 60s with our authentic Singapore hawker food fare such as Charcoal Fish Steamboat, Hainanese Chicken Rice Laksa, Fried Carrot Cake, Char Kway Teow, Seafood Hor Fun, Hokkien Mee and many more.

Enjoy these classic Singapore street fare in a refined and elegant dining atmosphere.

We also provide full catering service for corporate entertaining, lunch, tea and cocktail reception as well as social events

Address: # 110 CDEn St 360 boeng kongkangll, Chamkarmn, Phnom Penh , HP: 092 201 304, 017 821 480



Sarunya Lormaneenopparat, landscape architect and director of Sa.La.Design

Cambodia this is still the exception rather than the rule.

“As an architect, the best thing to do is to start from scratch and work with a designer from the start,” says Sara Hulten, an architect by profession. Her sister Frida agrees. “You can save money and time if there’s a dialogue in the network from the beginning, and you end up with a more satisfying and harmonious result.”

As a landscape architect, Sarunya experiences much the same. She’s married to a Cambodian architect and teaches part-time at the Department of Architecture at Norton University. “Foreign architects usually understand this and work together from the beginning,” she says. “But Khmer clients often build and only afterwards call us in.”

This absence of planning and vision can also be found on a greater scale.

“There’s a lack of infrastructure,” Rainer says. “You can’t build Camko City and

**There’s one thing to say ‘here’s the finished product’, and it’s another thing to value the thought process behind it.**

regularly shut down the electricity of parts of Phnom Penh, or build a Golden Tower without a solution for traffic.”

Sarunya agrees.

“When the economy booms, development sometimes happens too fast and the government cannot keep up,” she says. She thinks there’s too much construction with little regard for open spaces and green zones. “But then, there are not many real landscape architects around here, perhaps three or so.”

Bernard believes that the lack of government action is inevitable, given the nature of power within the country. “There are too many factions with too many visions,” he says. “They have difficulties to get what they want, there’s no outlined vision.”

Rainer would like to see more public discussion.

“In Europe the chambers of architects and engineers support the work of the government with their knowledge and experience of the urban development of the capitals,” he says. “This cooperation should start in Cambodia too.”

With the capital becoming increasingly crowded and traffic jams a routine part of daily life, Stephane Dawant believes that its inhabitants crave for a better quality of life. He sees this as an opportunity. “Now that the crazy building boom is over, there’s a chance for quality to emerge,” he says. “And the Cambodian mind is ready for that.” ■

# Moving Home

When most people move home they leave their house where it's standing. Not for **Darryl Collins**, co-author of *'Building Cambodia: 'New Khmer Architecture' 1953 to 1970'*. When he moved from Phnom Penh to Siem Reap he took his newly acquired wooden house with him – piece by piece. Then he reassembled it. Words by **Johan Smits** and photos by **Thomas Angus**.



**History and elegance**

A CAMBODIAN COUPLE RECENTLY made the headlines when they sawed their house in two because of a divorce dispute. But Darryl Collins wasn't divorcing when, in 2006, he had an entire house moved from a small island off Kampong Cham to the outskirts of Siem Reap.

The house in question, a Cambodian wooden home, was in danger of being torn down by its then-owners.

"I wanted to preserve this fine example of traditional domestic architecture," says Darryl, an Australian art historian and admirer of Khmer architecture.

## ■ FINDING THE RIGHT HOUSE

When his architect friend Hok Sokol, one of his co-authors on *'Building Cambodia: 'New*

*Khmer Architecture' 1953 to 1970'*, first came across the house in 2003, there was no talk of tearing it down. But a few years later, when it became too difficult for the head of the family who lived there to negotiate the stairs, Sokol was offered the house.

"It's a Chinese-Khmer house and that family had been living in it for three generations," Darryl explains. "They were a family of timber merchants so they were able to select good wood when they built it – five different kinds of it. It has lasted extremely well."

At the time Sokol knew that his friend Darryl was looking to move, and when Darryl went to look at the house in Kampong Cham, it was love at first sight.

It's easy to see why. Darryl's new home measures 17 metres in length and 9 metres

across, and some of its 24 wooden columns rise more than nine metres into the sky. Not that this labour of love was easy. It took Darryl and Sokol about 11 months to have the house dismantled, transported and rebuilt in Siem Reap.

"Sokol drew plans of the house on his computer. All the columns and cross-beams got lettered and numbered, like a giant jigsaw," Darryl explains.

## ■ THE REMOVAL MEN

As the house was located on an island, the two friends had to wait for the rainy season before they could pull it down piece by piece and carry everything onto small boats that would bring their load through canals to the edge of the island.





A reassembled masterpiece



Sokol drew plans of the house on his computer. All the columns and cross-beams got lettered and numbered, like a giant jigsaw

But only some small alterations have been made to make the house suitable for modern living. It hasn't lost anything of its former majestic grandeur. A large wooden panel separates the main space from the study, bedroom and mezzanine. It is decorated with elaborate hand-carvings, as are the outside window shutters and doors.

Darryl's own interior decoration only adds more elegance to the already magnificent structure of his new dwelling. Two splendid works by Khmer painter Leang Seckon dominate one side of the main panel, while books fill several wooden bookcases that are thoughtfully placed in the different spaces. The entire house with its dark, oiled wood exudes atmosphere. It makes you wonder why we live in brick and mortar houses.

"The entire palace in Phnom Penh was made of wood, until the French period

of wooden houses in the countryside. The question is to find them.

#### ■ THE FINAL VERDICT

So how has Darryl's living experience been since he made his move? "Many people said that I was going to find it difficult to live in this house because of the slated floor," he says. "The gaps would let in all sorts of bugs and mosquitoes. I have been in Cambodia for fourteen years and am used to a fair bit, but still, I also thought it would be a problem." Moreover, apart from the bedroom, the house is without air-conditioning.

However, in reality, Darryl says that his experience has been wonderful. "I haven't encountered any problems with mosquitoes because of the airflow through the house," he says. "They fly out as fast as they fly in. It's perfectly suited to tropical living."

What do his neighbours think of the strange newcomer who beamed up the wooden country house next-door? "Their reaction was surprisingly quiet," Darryl says. "But they both have wooden houses, so in the end it must not be that unusual for them." ■

"It was an enormous effort," Darryl recalls, "but the carpenters did a terrific job."

From there the load was transferred onto two larger ferries, then onto a big truck and finally onto hand-carts in order to reach its destination – a plot of land overlooking a small canal in Siem Reap. The same team of carpenters who dismantled the house reconstructed it again within a month.

"Some things we had to change," Darryl explains. "The kitchen was in too bad a condition to be saved."

when bricks, concrete and cement came into play," Darryl says. "The idea of more permanent structures for the capital city came in the nineteenth century. Since then elements of wooden architecture have been slowly disappearing." But according to Darryl there are still fine examples

PHOTOS COURTESY OF WWW.THOMASANGUS.COM/TEARSHEETS

# food corner

## Sweet and Rich Valentine

Valentine's Day is fast approaching and lovers across the city are making plans for the special day. Craig Gerard takes a look at those low-lit romantic hideaways.



True romance at Pacharan

VALENTINE'S DAY SEEMS to be growing more popular each year in Phnom Penh. Reservations are harder to get, flowers fly off the shelves, and the flurry of pink and red balloons can be blinding. The following restaurants all offer a quiet spot to connect with your lover. Many venues offer a special Valentine's Day menu. Make reservations early – many places will be booked solid that night.

### ■ KHMER SURIN

9 Street 57, Tel: 023 993 163

Let the lush garden and quiet tinkle of the water fountain whisk you away to tranquillity. The dark green of the abundant plants contrasts with comfortable red and orange cushions on the broad wicker and dark wood furniture to create a tantalising ambience. Book the South Gate portion for a more secluded experience. The green mango salad (US\$3) has a nice spicy bite, as does the basil stir fry with your choice of meat (US\$3). The tom kha soup (US\$5) will warm your mouth as well as your heart.

### ■ K'NYAY

25K Suramarit Road (St 268), Tel: 023 225 225

For the vegetarian or vegan Valentine, nothing beats K'nyay. Set back from the street in a relaxing garden, this restaurant exudes a rustic romanticism. With simple modern furniture, and dark interiors, you can melt into the couches after eating a fulfilling meal. The crunchy sweet corn fritters (US\$2) are delicious to share. The hearty, sweet potato pumpkin coconut curry (US\$5) is full of opposites – the yellow sauce contrasts with the dark wild rice and the sweet vegetables mix with the spicy curry. Save room for sticky rice with sweet mango (US\$3) to round off your meal.

### ■ LE DUO

17 Street 228, Tel: 023 991 906

Italians make good lovers, but

they also make great food, as evidenced at Le Duo. Dine poolside and witness plenty of naked bodies under the gaudy-but-fun Sistine Chapel replica, or slip inside for some air-con and candlelight. Sweet (and cheesy) love songs are sure to serenade you while you eat cannelloni al forno, duck and spinach stuffed pasta (US\$6.50 for a small plate) or a scrumptious calzone (US\$7.75). If you are looking to avoid heavy pastas, the sea bass (US\$9.50) is light and flaky, with a velvety butter sauce. No matter your choice, you're sure to find a good pairing from the deep wine list. For dessert, indulge in the fluffy tiramisu (US\$4.50). Close your eyes, and you can almost imagine you're next to the canals of Venice.

### ■ BAI THONG

100 Sothebros Blvd., Tel: 023 211 054

Not sure if you are in the mood for Asian or European cuisine? Head to Bai Thong, one of the only venues in town that simultaneously does both well. The quaint dining room has many pillars that create a sense of romantic seclusion. French onion soup is US\$4.50, or its Thai counterpart tom kha gai is US\$4.90. The pad thai (US\$5.80) is refreshingly authentic, and the tenderloin steak (US\$16.90) is juicy and well prepared. For a sweet and exotic dessert try the bua loi (US\$2.80).

### ■ PACHARAN

389 Sisowath Quay, Tel: 023 224 394

A wine-themed décor with vibrant reds and oranges awaits diners at Pacharan, and the funky Spanish grooves will turn your meal into a fiesta. Make reservations early to ensure you get a table on the balcony. Watch the Tonle Sap drift by while sharing a bottle of Spanish wine and flavourful



'Clink' at K'nyay



Van's - your table is ready

tapas. The calamares (US\$4.40) are a great starter and pair well with the chorizo a la plancha (US\$5.50). Nothing says "love" like sharing a paella de carne (US\$8.25/person). Top it all off with Catalan crème brûlée (US\$3.85) washed down with a glass of 'pacharan' liqueur.

■ OCEAN

11 Street 288, Tel: 012 176 6690  
Topping most expats' "I've been meaning to try that restaurant" list, Ocean will not disappoint. The kitchen churns out consistently good seafood. The stark-white walls adorned by abstract paintings are simple enough to avoid distraction from either date or plate. The tuna tartar (US\$6.50) served on a bed of arugula with a tangy citrus dressing is substantial enough for two. If it's fresh, the red snapper fillet (US\$10) is light and tender, with subtle Mediterranean spices. Reasonable wine prices (US\$20/bottle) will get your evening on the right track. Finish the meal with the airy chocolate mousse (US\$4) presented with cream and raspberry highlights.

■ VAN'S

5 Street 102, Tel: 023 722 067  
Stepping into this 150-year-old French Colonial building, you're in for something special. From the dark wooden columns to the symmetrical tables settings, the entire restaurant is geometric perfection. The servers

are attentive, but never hovering. For a treat, enjoy the foie gras stuffed raviolis (US\$9) or warm your throat with the thick French onion soup (US\$6.00). The rib-eye steak "Café de Paris" (US\$17) is meat of the highest quality, served with buttery gravy and au gratin potatoes. Unless a bottle on the wine list really catches your fancy, stick with a glass of Australian De Bortoli Shiraz-Cabernet (US\$4), which compliments many menu items. Hot on top and cold at the bottom, the raspberry crème brûlée (US\$5.50) is just as it should be.

■ LA RÉSIDENCE

22 Street 214, Tel: 023 224 582  
One of Phnom Penh's top restaurants, La Résidence combines elegance and luxury to create a one-of-a-kind dining experience. From the dining area, watch the water cascade down the window, sending twinkling lights straight to your table. Or for a more intimate setting, reserve one of their four private rooms. The menu is as impressive as the Khmer art adorning the walls. The green salad (US\$13.50) with papaya and smoked salmon dances on your taste buds. The rib of beef (US\$89 for two) is slow cooked and topped with your choice of house-made sauces. It pairs well with the Fleur de Cap Pinotage (US\$39.00). The passion fruit and lychee crème brûlée (US\$6) puts a local twist on the delicious dessert. 🍷



Love is fresh at Ocean

## Food Talk: A Brand New Riverhouse

With a revamped look, feel, menu and a new chef, the Riverhouse Asian Bistro & Lounge has redefined itself. **Craig Gerard** sat down with owner **Stephen Nyirady** to find out what this long-standing Phnom Penh hot spot has in store for us now.



Settling into a new standard of dining

“WE CREATED A RESTAURANT that we wanted to be at,” says Stephen of the original Riverhouse established in 2000. Back then, there were very few casual dining facilities in Phnom Penh serving great food. The result – instant success. As the riverfront area grew, so too did the Riverhouse, adding the lounge upstairs, expanding the restaurant, including French cuisine and a fine dining atmosphere. After eight years of

success, Stephen felt the need for a change.

“We’re not fine dining people,” says Stephen of he and his wife, who encouraged him into the restaurant business nine years ago. Instead of following the growing trend toward high-end, gourmet dining, Riverhouse has gone back to the basics.

### ■ THE FOOD

So what is new at the Riverhouse Asian Bistro? According

to Stephen, everything but the name. “It’s almost like opening a whole new restaurant,” he says. Being in an old French colonial building, he wanted the venue to maintain some of the European feel while using Asian influences as accents. The result is a fusion of the two cultures, which is reflected in the menu. Items like the Pork Penang Penne (US\$5) being a perfect example.

The original Riverhouse served Asian and Mediterranean cuisine,

which always sold well. The new menu is comprised of Asian food, and Western food with an Asian twist. With a wide variety of small plates, like the Duck Spring Rolls (US\$4.50), everyone can find something to suit their fancy.

### ■ THE DIGS

For Stephen it isn’t all about the food – the ambience at Riverhouse is one of the best along the riverfront. “This will be the place to be in the coming months.” He may be onto something. The giant-paned windows let you watch pedestrians navigating Sisowath Quay. The décor is modern and comfortable, with deep red cushioned chairs, oversized couches and pillows. Riverhouse is the kind of place you can sink into a comfortable seat and watch the hours pass by.

Possibly because of this reason, the bistro is staying open late. Midnight on school nights and later on the weekends. The goal is to more closely align the restaurant and the nightclub upstairs.

### ■ THE MAN

Over the past nine years, the Riverhouse has seen a number of transformations. The cards fall into place hearing Stephen talk about the restaurant in relation to his love for Cambodia. “I enjoy the process of building and developing places,” he explains of the constant remodels.

With plenty of restaurants along the River Front, what will keep customers coming back to the Riverhouse? “It is good value for the money,” Stephen says confidently. He continues, saying really it’s the entire package of ambience, food, drinks, good music, and good friends. It is easy to see where his confidence comes from. Stephen pours his heart into Riverhouse and his passion is contagious. “And,” he says with a grin, “our bartender makes the best mojitos in town.” ■

# New Year, New Delights for the Senses.

TOPAZ French Chef Alain Darc is pleased to announce the launch of his **new À La Carte menu**



EXCLUSIVE NEW TOPAZ SPECIALTIES INCLUDE:

**FINES TRANCHES DE VIVANEAU MARINÉES AUX TRUFFES**  
Thin slices of red snapper marinated with fresh truffles

**SCALPION DE LANGOUSTE EN RAVIOLI AU POIVRE VERT DE KAMPOT**  
Lobster ravioli in Kampot green peppercorn

**CASSOULET DU SUD**  
Traditional Southern stew with beans, pork sausage and assorted meats

**PIGEONNEAU FARÇI**  
Young pigeon stuffed with risotto, duck liver, morel mushrooms and vegetables

THE FRENCH CONNECTION™

**II TOPAZ®**  
RESTAURANT & PIANO BAR

182 NORODOM BLVD, PHNOM PENH, CAMBODIA  
TEL +855 23 22 16 22 HP +855 12 346 555  
manager@topaz-restaurant.com  
www.topaz-restaurant.com

POWERED BY **thalias**

# le quay Boutique café & crêperie



- crêpe
- panini
- waffle
- fish & chip
- greek salad
- mushroom soup
- ribs eye steak
- power juices
- energy smoothies
- segafredo coffees
- cocktails
- wines

Corner of Sisowath Quay & St. 110, Phnom Penh 023 213 582

## Fusion Sushi

ミックスすし料理

experience  
NEW RECIPES  
for 2009

No.18, Street 47 & 84 Phnom Penh

023 986 114

# restaurant guide

## key to symbols

- 01** Under \$3 per average dish **A/C** Air Conditioning
- 02** \$3 - \$6 per average dish Free home delivery available
- 03** \$6 - \$10 per average dish Free wireless Internet service
- 04** \$10+ per average dish ChildSafe®

ChildSafe®



A network protecting children from all forms of abuse. [www.childsafe-cambodia.org](http://www.childsafe-cambodia.org).

### cambodian

**Boat Noodle**  
8B Street 294, Tel: 012 774 287  
Khmer and Thai restaurant with excellent, well-priced food, set in a beautiful, traditional wooden house. Open 4pm to 10pm. **01**

**Frizz Café**  
67 Street 240, Tel: 023 220 953  
Dutch-run, restaurant specialising in authentic Khmer cuisine. Serves very good amok. Also runs its own cookery classes. **02**

**Green Pepper**  
6F Sotheros Blvd, Tel: 012 776 679  
Serving Khmer and Thai food in an elegant setting near the riverfront. Open from 10am to 2pm - 4pm to 10pm **02**

**K'NYAY**  
25K Suramarit Blvd., Tel: 023 225 225  
[www.knyay.com](http://www.knyay.com)  
A modern Khmer restaurant that is tucked away down an alley off of Sihanouk Blvd. The menu includes a selection of freshly prepared, vegan dishes, along with more traditional Cambodian specialties. K'NYAY also offers a selection of cakes, ice-creams and sorbets, using all vegan ingredients. **02**

**Malis**  
136 Norodom Blvd., Tel: 023 221 022  
[www.malisrestaurant.com](http://www.malisrestaurant.com)  
Beautiful modern Khmer restaurant with a courtyard set around narrow water channels and decorated with terracotta floor tiles. Inside there are four aircon rooms if the mid-day sun gets too much. The cuisine is modern Khmer, with no MSG, and is served elegantly in hollowed out palm tree bark. **04 A/C**

**Pon Loc**  
319 Sisowath Quay, Tel: 023 212 025  
Large, multi-storied restaurant serving Khmer food on the riverfront. Always seems to be filled out with locals and tourists alike. Open 10am to 12am. **02**

**Romdeng**  
74 Street 174, Tel: 092 219 565  
Recently moved to new location on Street 174 and run by the same NGO as Friends, this non-profit training school restaurant specialises in Khmer cuisine. Food has an appropriately fresh and daring flavour, especially if you opt for the crispy tarantulas as a starter. Good place to try fermented fish prahok. Open 11am to late. **02**

### chinese

**Hua Nam**  
753 Monivong Blvd., Tel: 016 899 555  
Large Chinese restaurant that specialises in seafood and duck. Has a good selection of wines. Has VIP rooms. **03**

**Man Han Lou Restaurant**  
456 Monivong Blvd., Tel: 023 721 966  
Cambodia's only micro-brewery with four types of German-style beer. Has extensive

Chinese, Thai, Khmer and Vietnamese menus, as well as dim sum breakfasts and excellent seafood. Features traditional Khmer dance performances nightly. **03**

**Mekong Village**  
290 Monivong Bvd.  
Large Chinese restaurant that specialises in crispy Beijing duck. Stays open until late in the morning. **02**

**Sam Doo**  
56-58 Street 128, Tel: 023 218 773  
The place for dim sum in Phnom Penh, baskets of steamed prawn dumplings, pork buns and more go for a mere US\$1.20. In addition wonton soup and other tasty meals are a steal. **01**

**Xiang Palace**  
Intercontinental Hotel, 296 Mao Tse Tung  
Upmarket restaurant with possibly the best range of Cantonese cuisine in town, served in opulent surroundings. **04 A/C**

**Yi Sang Chinese Restaurant**  
128F Sothearos Blvd., Tel: 023 220 822  
[www.almondhotel.com.kh](http://www.almondhotel.com.kh)  
Restaurant specialising in Cantonese food and dim sum that fuses the traditional with the contemporary, set on the ground floor of the Almond Hotel. Serves some of the best dim sum in town. Open from 6.30am to 10am, 11.30am to 2pm and 5.30pm to 10pm - dim sum not served in the evening. **03 A/C**

### french

**Atmosphere**  
141C Norodom Blvd., Tel: 023 994 224  
Well-established aircon restaurant serves fine French food in an elegant yet tastefully decorated setting. Close to Independence Monument. Open from 11am to 2pm and 6pm to 10.30pm. Closed Sundays. **03 A/C**

**Bougainvillier**  
277G Sisowath Quay Tel: 023 220 528  
Elegant, riverfront French restaurant using gourmet homemade ingredients, specialising in foie gras. Fish, beef, gourmet pasta dishes and langoustine also feature, plus a regularly changing specials board and excellent French wines. Three course set lunches are also available. Open from 6am to 10.30pm. Also has rooms upstairs. **03 A/C**

**Comme à la Maison**  
13 Street 57, Tel: 023 360 801  
Decidedly sophisticated French restaurant with a beautiful outdoor terrace area at the front, yet secluded from the street. One of the best French kitchens in town, shown by its popularity both at lunch time and at night. Small delicatessen at the back of the restaurant. Open from 6am to 10.30pm. **03**

**Elsewhere**  
175 Street 51, Tel: 023 211 348  
A beautiful garden with palm trees, bath-

# Bargain Bucket



## ■ CUP CAFÉ

Those who work at Pannasatra University are most likely familiar with cup café. It is hidden away in a small street opposite pencil supermarket near the riverside.

Although cup's prices are well within the bargain bucket's price range, this two storey establishment has the feel of a slightly more up market eatery. The doors are opened for you on arrival and the venue is roomy and comfortable. On entry you might notice two things: 1 – the

air-con can hit you in the face, and 2 – there is a slight gangsta feel here- many middle aged Khmer businessmen seem pepper the place. In my head at least, I am conscious of all sorts of shady dealings going down, but in reality, I am sure they are just talking about fluffy clouds and puppy dogs. If you happen to be visiting the cup for breakfast, you'll find the mornings seem to attract the military and policeman types. Accompanied by a constant stream of chatter from their walkie-talkies. So

if you are arriving at cup café on your moto make sure you don't have your head lights on at lunch or you might just find yourself paying for one of the policeman's meals.

Cup café offers a range of coffee's hot and cold starting from the rather obscure price of \$0.95. The range includes a coffee float featuring a scoop of ice cream atop your caffeine hit for \$2.20, and the coffee is strong. There is also a range of smoothies starting at \$1.70, including some odd flavours

such as taro, which may not sound particularly appetizing for some.

As far as food goes, cup café offers your standard noodles, noodle soups, as well as loc lac in either beef, pork, chicken. All meals range around US\$2, with some meals going for as high as a whopping US\$2.20. The chicken loc lac was fantastic and colourful and comes with fried rice and a bowl of broth on the side. Of course it comes with the usual concoction of MSG and pepper with lime that no plate of loc lac is complete without. The chicken itself is surprisingly tender, and the loc lac sauce was sweet without the usual garlic taste. With your little MSG it tastes great, even with the missing garlic flavours. Ice cream is also available at a steal for US\$1.20. The Khmer gangsta/businessman next to me seemed particular happy with his.

Overall cup café serves up quality food at affordable prices, in a setting that doesn't have the feel of a cheap nasty restaurant. Add to that the entertainment of the rich (and powerful?) Khmers chatting away on their walkie talkies and you've got yourself a fun filled lunch hour. The staff are pleasant, sometimes the English is not so good but you'll get there in the end.

*Cup Café South of Pencil on Sisowath, behind Hong Kong Centre off of Sotheaeros. Tel: 012 859 666 – ADAM FITZGERALD*

**La Croisette** international bar & restaurant since 1997 - 241 Quai Sisowath - Phnom Penh - Tel: 023 220 554



free Wifi  
great coffee / breakfast / lunch / dinner  
happy hour 8pm - 10pm:  
cocktails \$ 3.50  
Tiger beer \$ 1.50  
every Wednesday 8pm: Live music  
every 1st Saturday: Soundz of Berlin  
(hosted by DJ Nico from Metahouse)



# popcafe

## DA GIORGIO

*Italian Managed*  
Air-con Dining  
Authentic Italian Cuisine  
Homemade Pasta, Gnocchi, Pizza, Lasagna

Lunch: 11 am - 2:30 pm  
Dinner: 6 pm - 10 pm  
*Eat in or take away*  
#371, Sisowath Quay, Next to FCC Tel: 012 562 892



## Le Rit's Restaurant

Asian and European Cuisines  
Catering Service

House No. 14, St. 310, Phnom Penh  
Tel: 023 23 160



FRANCOIS  
SYMBOLS  
2008  
IMPERIA  
2008  
SYMBOLS

Looking for something *different?*  
Visit us for fine wines and *more!*

# QP

Quarto Products  
FINE FOOD & WINE DISTRIBUTOR

#30 & 31 St. 108, Sangkat Wat Phnom, Khan Daun Penh, Phnom Penh  
Tel: +855 (0)23 221 772 Fax: +855 (0)23 221 770

333 Slorkram Village, Slorkram Commune, Siem Reap  
Tel: +855 (0)63 760 865 Fax: +855 (0)63 760 866

sized swimming pool and luxurious reclining couches makes you feel anywhere else than in the centre of town. A separate restaurant has a simple menu, although dining Romano-style is far cooler. Open 10am to late. Closed Tuesdays. **02**

**La Croisette**  
241 Sisowath Quay, Tel: 023 220 554  
Riverfront restaurant with an ample outside dining area screened off by trees. Good, reasonably-priced, French cuisine with excellent barbecues, as well as Asian and Khmer food. Newly redecorated with more indoor air-con space. Open 7am to late. **02 A/C**

**La Marmite**  
80 Street 108, Tel: 012 391 746  
This small, reasonably priced French bistro has two adjoining rooms, one non-smoking. Relaxed, cosy atmosphere. Serves excellent fish, steaks and offal as well as daily specials, but no Marmite! Open 11am to 2.30pm & 6pm to 11pm. **02 A/C**

**La Residence Restaurant**  
22/24 Street 214, Tel: 023 224 582  
Fine dining on an international scale in this sophisticated restaurant, where French classics meet gourmet, modern cuisine. Open for lunch and dinner Mondays to Fridays, and dinner only on Saturdays and Sundays. **04 A/C**

**Le Jardin**  
16 Street 360, Tel: 011 723 399  
Beautiful shaded restaurant with large garden and spacious outdoor play area for kids. Serves excellent ice cream. Open 7am to 6pm. **02**

**Tamarind**  
31 Street 240, Tel: 012 830 139  
Bold Mediterranean / North African restaurant set on three floors which serves couscous, tagines, chawarma, tapas and mezze. Small bar with pool table downstairs denies the elegance upstairs, especially the roof terrace, which opens after sunset. Open 10am to 12pm. **03 A/C**

**The Wine Restaurant**  
219 Street 19, Tel: 023 223 527  
Excellent fine dining restaurant in the same grounds as Open Wine. The fresh food and extensive selection of wines make this one of the more exclusive places to dine in town. **04 A/C**

**Topaz**  
182 Norodom Bvd. Tel: 012 333 276  
Sophisticated, aircon restaurant with outside dining, upstairs bar, wine shop, cigar room and private rooms. One of Phnom Penh's finest restaurants. Open 11am to 2pm and 6pm to 11pm. **04 A/C**

**Van's Restaurant**  
5 Street 102, Tel: 023 722 067  
French fine-dining in a grand setting awaits at Van's, located on the second floor of a well preserved colonial era building near the city's Post Office. Open every day from 11.30am to 2.30pm and 5pm to 10.30pm. **04 A/C**

### indian sub-continent

**Annam**  
1C Street 282, Tel: 023 726 661  
Beautiful terracotta terrace and garden Indian restaurant, offering north and south Indian cuisine, with open kitchen, separate aircon restaurant and kids' playpen. Separate north and south Indian menus. Open from 11am to 3pm & 6pm to 11pm. Closed Tuesdays. Free home delivery. **03 A/C**

**Dosa Corner**  
15 Street 51, Tel: 012 673 276 Street  
This small south Indian restaurant opened in January. True to its name it has a wide range of very good value dosa (US\$1 to US\$2) as well as thali and biryani dishes (US\$2.50 to US\$4). Air-conditioned, it's open from 7.30am to 11pm. **02 A/C**

**East India**  
9 Street 114, Tel: 023 992 007  
Predominantly South Indian cuisine in this pristine restaurant. Excellent breads including 9 types of dosa. All-you-can-eat vegetarian Sunday special for US\$4. **02 A/C**

**Flavours of India**  
158 Street 63, Tel: 012 886 374  
Relaxing Indian and Nepalese restaurant with friendly staff and a good range of dishes. Both the vegetarian and meat thalis are good value. Open 10am to 10pm. **02 A/C**

**Saffron**  
11 Street 278, Tel: 012 247 832  
Pakistani and Middle Eastern café, restaurant and wine bar. The curries are excellent and not too spicy, and come with a range of breads and chutneys. The wines have a bias towards the antipodes, including possibly the best range of wines by the glass in town. Open 11am to 11pm. **02 A/C**

**Shiva Shakti**  
70 Sihanouk Bvd., Tel: 012 813 817  
Decidedly upmarket and sophisticated Indian restaurant in a beautiful setting with prices to match. Good place for an Indian treat, especially the tandooris. Open from 11am to 2pm and 6pm to 10.30pm. Closed Mondays. **03 A/C**

### international

**Art Café**  
84 Street 108, Tel: 012 834 517  
Elegant bistro and art gallery in the style of a European coffee house. German flame cakes and eau de vie as specialties. Features art exhibitions and classical music performance. Open from 11am to 11pm. **02 A/C**

**Billabong**  
5 Street 158, Tel: 023 223 703  
Excellent western and Asian food which comes with a dip in the hotel's beautiful pool. Open from 6am to 9pm. **02**

**Bodhi Tree**  
50 Street 113  
Relaxed garden atmosphere and open balcony restaurant with an imaginative menu. Right opposite Tuol Sleng. Open 9am to late. **02**



**Aromatic & Flavorful**

# Cambodian Pepper

OPEN; Everyday (Exp. WED)  
8:00~19:00



St.63 ⊥ St.322, BKK 1, Phnom Penh  
TEL&FAX 023-726480 H/P 012-842970  
customer@ksline-cambodia.com  
http://www.ksline-cambodia.com





**Cadillac Bar & Grill**

219E Sisowath Quay, Tel: 011 713 567  
Air-conditioned riverfront bar which promises a hassle-free drink. Mixing up burgers, pasta and some Asian food with Blues and rock and roll, this American-style bar serves good hearty food. Open 8am to 1am. **03 A/C**

**Café Living Room**

9 Street 306, Tel: 023 726 139  
Set in a stylish villa, Living Room has healthy salads and snack plates, plus a great tea and coffee menu. Has a kid's playroom and baby changeroom. Uses organic and fair trade produce. Open everyday from 7am to 8.30pm. **02 A/C**

**Del Gusto**

43 Street 95  
Beautiful colonial setting makes a perfect seting for the Mediterranean-inspired menu. Run by the same people as Bodhi Tree. Open 7am to 9pm. **02**

**Edelwiess Restaurant**

375 Sisowath Quay, Tel: 092 341 329  
This open-air restaurant specialising in German and Khmer food offers the perfect spot to enjoy an Erdinger beer while watching life go by on the riverfront. **02**

**FCC Phnom Penh**

363 Sisowath Quay, Tel: 023 724 014  
Phnom Penh's landmark restaurant, with sumptuous views across the river on one side and the National Museum to the other. It's best to come at sunset when the streets below are most crowded, the cocktails are half price and draft beer goes for US\$1. Open 7am to midnight. **03**

**Flavours**

Cnr. Street 51 & 278, Tel: 012 175 896  
Relaxing restaurant and popular bar run by two Quebecois with comfortable chairs falling onto the street. The mix of Asian and western cuisine has proved so popular that they have a copycat restaurant opposite. Open 7am to late. **02**

**Freebird**

69 Street 240, Tel: 023 224 712  
Aircon American bar with neon lighting, a variety of memorabilia, comfortable seats, rock music. International menu with good lunch offers, an excellent range of bottled sauces, excellent International, Mexican food and burgers. Be prepared for some good solid R&R. WiFi is available, but there is a small charge. Open 7am to midnight. **02 A/C**

**Friends**

215 Street 13, Tel: 012 802 072  
Non-profit training restaurant where all the proceeds go to the neighbouring street-kid school. Food is a reliable mix of Mediterranean and Asian with tapas thrown in if you are not feeling too hungry. Great juices. Another one of Phnom Penh's places designed to take it easy, but this time with a clear conscience. Open 11am to 9pm. **01**

**Garden Center Café**

Street 108, Tel: 023 997 850  
Garden Center Café 2  
www.gardencentercfe.com  
Popular expat restaurant with fresh ingredients and lots of healthy options. Open from 7am to 10pm. Closed Mondays. **02**

**Garden Center Café 2**

23 Street 57, Tel: 023 363 002  
www.gardencentercfe.com  
More compact version of the Garden Center is conveniently located close to the popular Street 278. Open from 7am to 10pm. Closed Mondays. **02**

**Gasolina**

56/58 Street 57, Tel: 012 373 009  
Largest garden bar and restaurant in town. Extensive menu includes a Saturday brunch and BBQ, and Sunday brunch with crêche facilities. Open from 11am to late. **02**

**Green Mango**

Cnr. 63 & 278, Tel: 016 821 303  
Very green décor for this corner plot that

used to be Tom's Bar. Serving a mix of Khmer and western dishes in a relaxing atmosphere, it's open from 7am to midnight. **02**

**Green Vespa**

95 Sisowath Quay, Tel: 012 887 228  
Arguably the best pub grub in town and guaranteed never to send you home hungry. Country pub style menu with wide range of breakfasts. Special food offers each night of the week with a range of alcohol for US\$10. Open 6pm till late. **02 A/C**

**Gym Bar**

42 Street 178, Tel: 012 815 884  
The best sports bar in town also has reasonable food. Good burgers, curries and an ignominiously named Joel Garner hot dog. Open 11am to late. **02 A/C**

**Huxleys**

Cnr. of Streets 136 & 5, Tel: 023 986 602  
Wood-pannelled traditional English pub downstairs serving pub grub, international restaurant located on the first floor. Abundance of water features creates a soothing place to dine out. **03 A/C**

**Irina Russian Restaurant**

15 Street 352, Tel: 012 833 524  
Russian restaurant of iconic Phnom Penh status. If you can walk out of the restaurant after hitting the vodkas then you are doing well. Open 12pm until the vodka runs out. **02**

**Jaam**

Cnr. of Sisowath Quay & Street 106  
Latest venture from the owners of the popular Flavours Restaurant and Liquid Bar on Street 276, this river-fronted restaurant spills out on the pavement providing a great vantage point to see the night market unfold. Meaning 'plate' in Khmer it has an extensive menu of Asian, Khmer and international cuisine. **02**

**Java Cafe & Gallery**

56 Sihanouk Bvd., Tel: 023 987 420  
Great coffees, salads, mix-and-match sandwiches and juices served in an

elegant setting. The terrace, which overlooks the Independence Monument, is a good place to sit and while away your afternoon. The relaxed inside dining area has a small gallery attached to it with exhibitions of Cambodian photography and art. Open 7am to 10pm. **02 A/C**

**K West**

1 Street 154 (Cnr. Sisowath Quay)  
Tel: 023 214 747  
Stylish aircon bar and restaurant below the Amanjaya with an excellent steak menu and good value happy hour from 6pm to 8pm Fridays. Now has a brasserie menu with daily specials. Also has free Wifi. Open 6.30am to midnight. **03 A/C**

**Le Quay Café**

Cnr. Sisowath Quay & Street 110,  
Tel: 023 213 582  
www.amaraspahotelcara.com  
The restaurant side of Amara Spa specialises in 28 varieties of crêpes (US\$2.50 to US\$8) with salads (US\$3 to US\$4.50) and panini (US\$3.50 to US\$6) also featuring strongly on the menu. Le Quay is a very healthy addition to the riverside scene. Open from 9am to 8pm. **02 A/C**

**Le Rit's**

14 Street 310, Tel: 023 213 160  
Restaurant and boutique handicraft shop run by the NGO NYEMO, set in a beautiful garden, the restaurant specialises in Asian and European cuisine. Open from 7am to 5pm, closed Sundays. **02**

**Madeleines Bakery**

19 Street 228, Tel: 012 988 432  
A bakery and restaurant offering a variety of baked goods as well as organic lunches and catering services. Open Monday to Saturday 8am to 5pm. **02**

**Metro Café**

Cnr. Sisowath Quay & Street 148  
Tel: 023 222 275  
Stylish Metro has much more than cool décor and changing light boxes. Contempo-

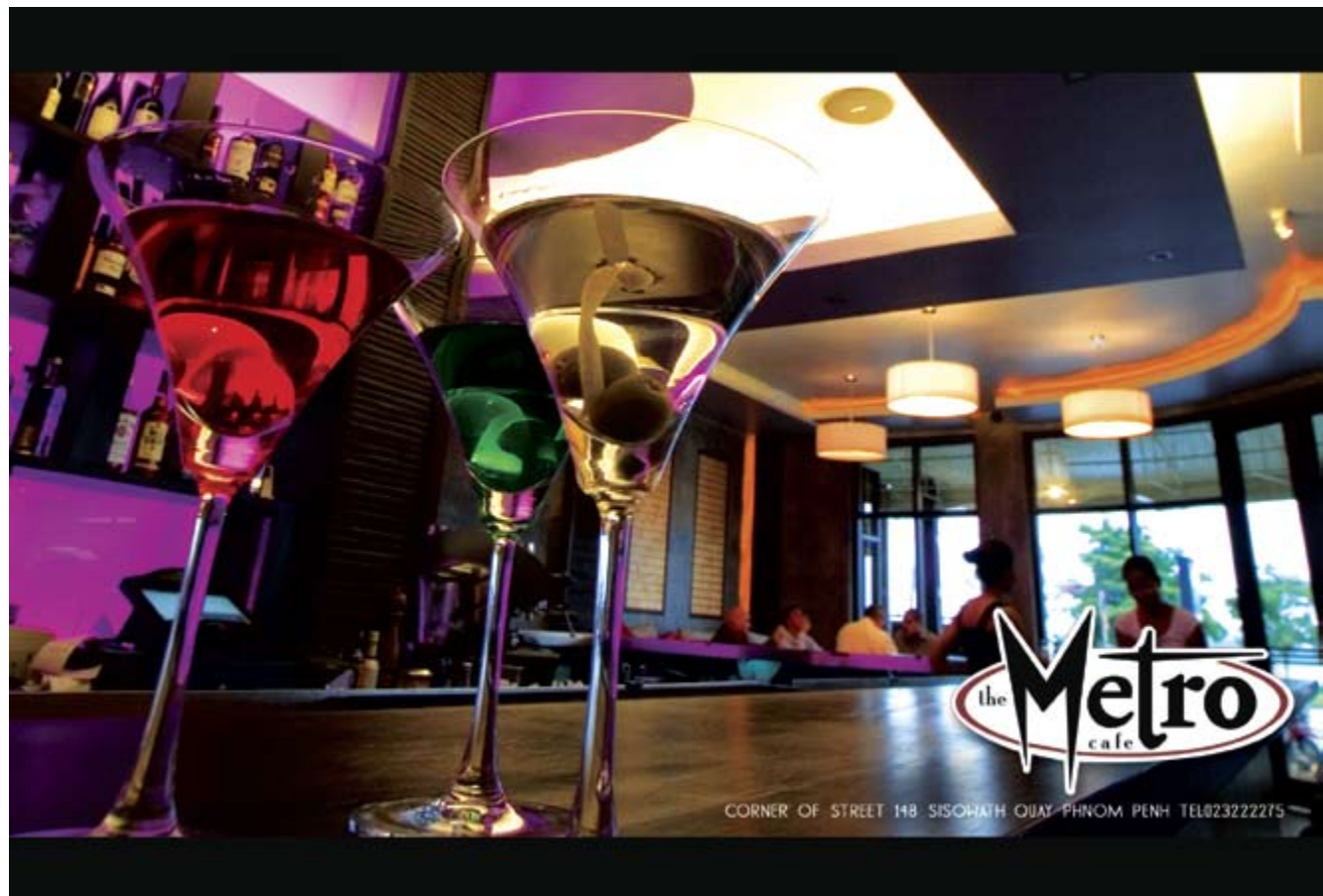



**BONG KAREM**  
Italian gelato

**Delivery Monday to Saturday 11:00 am - 5:00 pm**

**Gelato supply to restaurants & bakeries**

**Mobile Gelato display case for junctions & parties**

**Bong Karem Shop @ WarpZone, Pencil Supercenter (opposite Cambodiana Hotel)**

**Tel: 092 23 53 36 | bongkarem@web.de**



**The Tamarind**  
MEDITERANEAN BAR & RESTAURANT

**Oriental Elegance**

Three floors: Bar, A/C Restaurant and Rooftop terrace, offering **Oriental and French** cuisine. Specialties: Tapas, Couscous, Tagines, Chawarma, Kebabs. Happy hour from 3pm until 7pm: cocktails 50% off. Credit cards accepted. # 31 Street 240, Tel: 012 830 139: reservations catering - home delivery



**GB**

**La Gourmandise Bleue Patisserie**

The Chef offers you quality of produces carefully prepared by himself.

**Pastry : Macarons (18 flavours), chocolates, croissants, cakes and oriental pastries, birthday cakes.**

**Caterer : Tunisian couscous by order, sandwiches, taboule, salads.**

**Open from Monday to Sunday, 7:00am - 8:00pm.**

159 EO Street 278 (behind Lucky supermarket), Phnom Penh  
Tel : 023 99 40 19 - 012 160 30 40

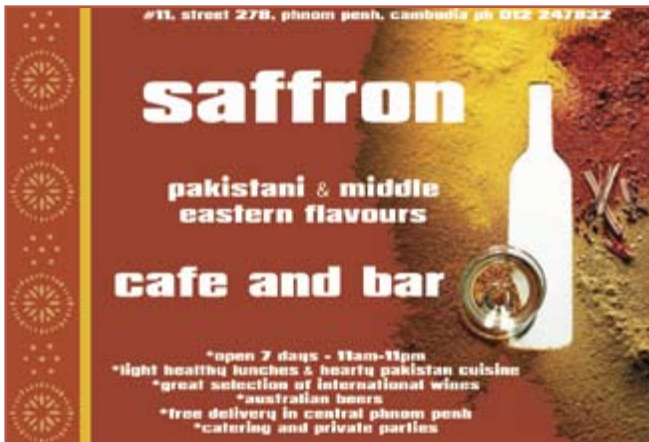

#11, street 278, phnom penh, cambodia ph 012 247822

**saffron**

**pakistani & middle eastern flavours**

**cafe and bar**

\*open 7 days - 11am-11pm  
\*light healthy lunches & hearty pakistani cuisine  
\*great selection of international wines  
\*australian beers  
\*free delivery in central phnom penh  
\*catering and private parties

rary Asian and western dishes on a manageable menu divided into small plates, grills, salads, soups and large plates. Also has reasonably priced Tiger, house wines and a great range of Martinis. try the Espresso and you'll never look back. Free Wifi. Open 10am to 2am. **03 A/C**

**Nature & Sea**  
Cnr. Street 51 & 278 Tel: 012 195 3810  
Laid back eatery overlooking Wat Langka. Serves many types of fish dishes as well as some great crepes. Also sells some take home organic produce. Open from 8am to 10pm. **02**

**Ocean**  
11 Street 288, Tel: 012 176 6690  
European managed Mediterranean restaurant that dishes up some of the best fish and seafood in town. Try the red snapper or the squid with rocket. Often has exhibition around the understated walls. **03**

**One More Pub**  
16E Street 294, Tel: 017 327 378  
English-style bar with comfortable wooden bar stools, filled with traditional paraphernalia and enough flags to make the UN envious. No hip hop nor techno music, instead hearty Teutonic fare. Open from 5pm to late, happy hour from 5pm to 7pm, closed Tuesdays. **03 A/C**

**Pacharan**  
389 Sisowath Quay, Tel: 023 224 394  
Barcelona comes to Phnom Penh via London's Mayfair in this exquisite up-market bodega. Airon restaurant that specialises in tapas and fine Spanish wines. Set in a beautiful colonial building with great decor, an open kitchen and sweeping views of the river, Pacharan is one of Cambodia's finest. Second branch in Ho Chi Minh City. Open from 11am to 11pm. **02 A/C**

**Pickled Parrot**  
4-6 Street 104, Tel: 012 633 779  
[www.tonlesappuesthouse.com](http://www.tonlesappuesthouse.com)  
Airon bar with an excellent 9-ball pool table. 24-hour satellite sports channel. Reliable international and Khmer cuisine is available at the bar. Open 24 hours with free WiFi. **02 A/C**

**Restaurant Tell**  
73 Street 90, Tel: 023 430 650  
Up-market eatery that re-creates the genuine feel of an Alpine chalet. Older sister to its namesake restaurant in Saigon's District 1, it has a spacious indoor restaurant and outdoor terrace with rotisserie and bar. European menu with imported steaks, fondue, raclette and an extensive wine list. **03 A/C**

**Rising Sun**  
20 Street 178, Tel: 012 970 719  
English-style pub with good breakfast, meat pies and hamburgers. Has a regular following at night especially on Fridays. Great posters of British films and TV classics adorn the walls. Ideal for that touch of nostalgia and the fish and chips are good, although not wrapped in newspaper. Open 7am to 10pm. **02**

**Riverhouse Restaurant**  
6 Street 110, Tel: 012 766 743  
Sophisticated restaurant with a welcoming outside seating area that serves up a mix of Asian and western food, including couscous. Has a nightclub upstairs. **03 A/C**

**Riverside Bistro**  
Cnr. Sisowath Quay & Street 148, Tel: 012 277 882  
Popular restaurant with expats and tourists alike mainly due to its large outdoor terrace area to view the river. Serves a mixture of Asian and western food with an emphasis on German cuisine. Has rock music videos and a pool table in the Mata Hari pub at the back. Open from 7am to 2am. **02**

**Sarika**  
69 Street 566, Tel: 017 456 116  
Set in the most beautiful traditional wooden house in Tuol Kork, Sarika has an aura of elegance. Spacious gardens provide an excellent setting for the range of BBQs. Specialises in skewers, seafood steak and Asian cuisine. VIP rooms upstairs. **03 A/C**

**Scoop Bistro Bar**  
2-6A Regency Square, Mao Tse Tung Blvd., Tel: 023 424 457  
Elegant, chic bistro with a simple, yet refined black and white design with comfortable, high-backed dining chairs providing seclusion from other diners. Wonderfully conceived menu with homemade pasta and varied selection of vegetarian dishes. Slightly raised lounge area is ideal for cocktail or coffee. Has three private rooms. Open from 11.30am to midnight, closed Sundays, reservations recommended. **04 A/C**

**Steve's Steakhouse**  
20 Street 51, cnr. Street 282, Tel: 023 987 320  
Longstanding restaurant specialising in local grain-fed beef as well as a large variety of imported steaks, hamburgers, ribs and Greek cuisine. Has a terraced lounge with pool tables upstairs as well as a sports bar with large screen TV. Happy Hour from 12pm to 7:30pm. **02 A/C**

**Talkin to a Stranger**  
21B Street 294  
Cosy garden restaurant cum bar using imported Australian and local products. Menu changes regularly and Thursday night is special roast lamb night. Excellent cocktails menu. Open 5pm to late. **02**

**The Kitchen**  
17 Street 148, Tel: 092 986 951  
With a simple décor, this restaurant specialises in exotic meats - ostrich, crocodile and kangaroo. The Khmer set including beef, chicken, pork, squid and crocodile is US\$8, the half-ribs are US\$5 and full-ribs are US\$8. There's also a BBQ every day at 6pm with ribs, kebabs and brochettes. Open from 8am to 2am. **02**

**The Shop**  
39 Street 240, Tel: 092 955 963  
Stylish café, with a wide range of fresh bread, tempting patisseries and juices, excellent salads and sandwiches. Crowded at lunchtime, but the small, cool courtyard at the back creates a



**Japanese Kitchen**  
**Mr. Sushi & Kokoro**  
**Sushi Buffet \$11 Only (Every Night)**

Salmon roll, Tuna sushi, Tempura

**25 Kinds of Food!**

**Big private room (up to 17 people)**  
Placed in front of Monument park

**Eo 18 Shihanouk Blvd, Phnom penh, 012 601 095**

# Review: Le Rit



INITIATED BY THE NGO Neymo, Le Rit's was established as an effort to provide vocational training to at-risk women of the Phnom Penh community. The restaurant setting which is filled with fern trees and hanging orchids encourages a remarkable amount of butterflies to hang about while you enjoy your meal.

Le Rit's offers two set menus to choose from for \$6, and you can mix and match components of the two. One of the starters on offer was grated carrot which comes with an olive oil dressing and boiled egg – no frills there. The other option was deep fried cheese which is encased in some sort of doughnut style batter. Not overly oily and the serve size is just right, as you don't want to be full of cheese before you reach the main course.

For the mains you can choose from a casserole with pasta or fish with ginger and rice. The fish is satisfying but could do with a little something else as it is on the slightly bland side.

As for the deserts, you have the choice of homemade custard or a rather tasteless fruit salad which consist of nothing more than a little dragon fruit, pineapple, papaya and some apple. Though refreshing in the heat, there is not much ex-

citement for your taste buds. The homemade custard may have been the way to go.

Le Rit's also offers a variety of fruit juices including Orange and Pineapple, Guava, Coconut, carrot, and grapefruit all at US\$1.50.

For the price of US\$6 the food is quite reasonable but don't expect to be blown away. The garden setting however, makes it worthwhile being away from the busier lunch time haunts and allowing you to escape the crazy lunch time traffic. With the staff also being most accommodating and prompt providing you with an easy trouble free morning or lunch time meal.

Neymo also has a variety of handicrafts for sale including bags, wall hangings and numerous nick-nacks to decorate your home. Le Rit's is also a guest house, albeit a small one. Consisting of three rooms you will be guaranteed some peace and quiet during your stay. Rooms range from US\$35 to US\$45 and include free breakfast, internet and laundry. All rooms have air-con and cable TV, and room service is available during restaurant hours.

*Le Rit's is located at #14 St 310 BKK1 and is open from 7.30 am till 5p.m. Ph: 023 213 160 or email on sales@nyemo.com. 📍*



*purely*  
**MAGNIFICENT**



*simply*  
**EXCEPTIONAL**



**Open everyday**

11:30 am to 02:30 pm

05:00 pm to 10:30 pm

**023 722 067**

**vans.icb@gmail.com**

No 5, street 102,

Place de la Poste - Main Post Office

Phnom Penh

**Gastronomic French Cuisine**



# Steve's Steakhouse & Greek Restaurant

*Something for Everyone!*

Large variety of Western Cuisine & Quality Selection of Local Dishes.

#20Eo, Corner of St. 51 & St. 282  
Tel. 023 987 320

THE TASTE

## OCEAN

MEDITERRANEAN CUISINE



EUROPEAN MANAGED  
FINEST SEAFOOD & MORE

Open Daily from 12 PM-2 PM/6 PM-10 PM  
Street 288, #11, PNH / Tel: 017 766 690



# DOSA CORNER



*Specialised in south indian dishes at affordable price*

*15 Varieties of dosa to choose from*

*For Home Delivery and Party Order Please call 012 673 276*

NO. 5E, STREET 51, WAT LANGKA, PHNOM PENH, CAMBODIA

perfect haven from the sun. Open 7am to 7pm Monday to Saturday and 7am to 3pm Sunday. **02**

**Velkommen Inn**  
23 Street 104, Tel: 092 177 710  
Comfortable hotel restaurant and bar, the Velkommen Inn, just off the riverfront, offers a wide selection of western dishes as well as several Scandinavian specialties with a full bar, draught beer, wine and sprits. Open 7am till late. **02**

**Wine Garden**  
219 Street 19, Tel: 023 223 527  
Outdoor garden restaurant at the front of Open Wine. BBQ meat, fish and seafood as well as Fanny ice-cream. Excellent wines by the glass or bottle. Open 9am to 11pm ever day. **02**

**The Winking Frog**  
128 Sotheaors Blvd., Tel: 023 356 399  
Large air con British-run pub with live band and DJs at weekends. Thai Chef preparing pub grub, Thai and Khmer food and large slate, 9-ball pool table at the back, this place offers something for everyone. Has a 31-room guesthouse upstairs. Open 24 hours. **02 A/C**

**Italian**  
**La Volpaia**  
20-22 Street 13, Tel: 023 992 739  
Part of a global pizzeria chain that includes Florence, Tokyo, Seoul and Phnom Penh. Good terrace area and inside aircon room. The cuisine is excellent with pizza and pasta cooked fresh in front of your eyes. **03 A/C**

**Le Duo**  
17 Street 228, Tel: 012 342 921  
This beautiful restaurant has the option of sitting outside or inside in air-con. Excellent wood-fired pizzas and pasta. Friendly Sicilian owner will guide you through the extensive wine list. Open from 11.45am to 2.15pm & 6.15pm to 10.15pm. **02 A/C**

**Luna d'Autunno**  
6C Street 29, Tel: 023 220 895  
Beautiful courtyard or stylish interior air-con restaurant, whichever you choose, Luna has more classical pizzas, both red and white, to choose from than most restaurants. Also serves excellent pasta and other up-market Italian food. Good wine cellar on view in the restaurant. Open 11am to 2.30pm and 5.30pm to 10.30pm. **03 A/C**

**Pop Caf **  
371 Sisowath Quay, Tel: 012 562 892  
A sophisticated, small Italian restaurant located next to the FCC that serves light, contemporary Italian cuisine including fresh pasta and pizzas. Extremely popular with expats. Open for lunch from 11.30am to 2.30pm and 6pm to 10pm for dinner. **02 A/C**

**Japanese & Korean**  
**Fusion Sushi**  
18 Street 47, Tel: 023 986 114  
Located inside of Cara Hotel. Beautifully decorated, impeccable service. Serves

excellent quality Japanese and Korean sushi. **04 A/C**

**Le Seoul**  
62 Monivong Blvd.  
Popular up-market South Korean restaurant specialising in BBQ. Each table is equipped with its own charcoal burner. All beef is imported from the U.S.. Open from 11am to 2.30pm and 5pm to 10pm. **03 A/C**

**Mr. Sushi & Ko Ko Ro**  
18 Sihanouk Bvd., Tel: 012 601 095  
Affordable, canteen-style restaurant with lots of specials dotted around the walls. Charismatic owner has a copious supply of Japanese vodka. Open 11.30am to 2pm and 5.30pm to 9pm. **02 A/C**

**Origami**  
88 Sotheaors Bvd., Tel: 012 968 095  
Up-market, contemporary Japanese restaurant with a spacious air-con area downstairs and four private rooms upstairs. Specialises in sushi and tempura, and has Asahi, Kirin and Sapporo beers. Open from 11.30am to 2pm and 5.30pm to 9.30pm. **03 A/C**

**Pyeongyang**  
400 Monivong Bvd., Tel: 023 993 765  
Phnom Penh's only North Korean restaurant has cultural shows starting at 8pm each night. The kim chi is excellent too. Unforgettable experience. Open from 11am to 11pm. **03 A/C**

**mexican & tex-mex**  
**Alley Cat Caf **  
Cnr. of Streets 19, 178, Tel: 012 306 845  
Small, friendly patio caf  serving good Mexican food and claiming to have the biggest burgers in town. Hard to find, Alley Cat is tucked down an alley at the back of the National Museum, the first on the right if you are coming from Street 178. **02**

**Cantina**  
347 Sisowath Quay, Tel: 023 222 502  
A mainstay of the riverside scene, this is a popular meeting place for local expats. Serves good Mexican fare and features photographs that capture the changing face of Cambodia. Open 3pm to late, closed on Saturdays. **02**

**Sharky Bar**  
126 Street 130, Tel: 023 211 825  
[www.sharkysofcambodia.com](http://www.sharkysofcambodia.com)  
Not just a pretty face, the biggest and most famous of Phnom Penh's bars has one of the best bar menus in town. The burritos and burgers are extremely good, although of gargantuan proportions. Open 4pm to 2am. **02**

**thai & pan-asian**  
**Anise Terrace**  
2C Street 278, Tel: 023 222 522  
Beautiful terrace restaurant serving up South-East Asian cuisine. Does excellent value breakfasts and also sells New Zealand ice cream. Open 6am to 11pm. **02**



**CHICK FOR SIX**  
NOW FULL TANDOOR CHICKEN  
**\$ 6.00 ONLY @ ANNAM**

**ALL DAY HAPPY HOUR**  
11.00 am - 11.00 pm  
**ANGKOR DRAFT**  
BUY 1 GET ONE **\$ 1.00**

**FREE WI-FI**

**Annam**  
The Indian food place  
1C St. 282, Phnom Penh

For enquiry & reservations  
Tel: 023 726661 Mobile: 099 926661

**Bua Thai**

Ground Floor, Phnom Penh Hotel, Monivong Blvd. Tel: 023 990 098  
Over 200 dishes provide a wide range of delights in this surprisingly good Thai restaurant. The sauteed prawns with chuchee chilli paste are divine. **03 A/C**

**Chow**

277 Sisowath Quay, Tel: 023 224 894  
Contemporary and sophisticated riverfront restaurant that serves southeast Asian cuisine, a wide range of cocktails, juices and Illy coffee. Great place to have a drink during its half-price 4pm to 8pm happy hour. Open 7am to 11pm. **04 A/C**

**Lemongrass**

14 Street 130, Tel: 012 996 707  
Elegantly designed Thai-managed restaurant that serves Thai and Khmer cuisine. Aircon with stylish use of heavy wood and artefacts to create a far more luxurious ambience than the reasonable prices would suggest. **02 A/C**

**Le Wok**

33 Street 178, Tel: 092 821 857  
Light and modern pan-Asian and French eatery with dishes such as prawns with lime and wasabi and Mekong lobster thermidor. Comprehensive wine list and cocktails. Open Daily from 9am to 11pm. **03**

**Mt. Manaslu Muraa's Café**

1a Street 282, Tel: 012 176 0740 or 023 996 514  
Serving up great Nepalese and Indian food at affordable prices with both open-air and air conditioned dining areas.

**Regent Park Hotel**

58 Sothearos Blvd., Tel: 023 427 131  
Little known but excellent Thai restaurant that serves well prepared and wonderfully spicy dishes. A subdued elegant setting and reasonable prices make this a real find. **02 A/C**

**Singapore Kitchen**

110 Street 360, Tel: 092 201 304, 017 821 480  
Specialising in classic Singapore hawker food, the new improved Kitchen has a more relaxing atmosphere than its previous incarnation. Try the laksa – full of wholesome ingredients and with a great spicy, creamy sauce – those wanting a more subtle flavour could do worse than trying the Hainanese chicken rice. Open from 11am to 9.30pm, does delivery. **02 A/C**

**The Winking Frog**

128 Sothearos Blvd., Tel: 023 356 399  
Large air con British-run pub with live band and DJs at weekends. Thai Chef preparing pub grub, Thai and Khmer food and large slate, 9-ball pool table at the back, this place offers something for everyone. Has a 31-room guesthouse upstairs. Open 24 hours. **02 A/C**

**Café Living Room**

9 Street 306, Tel: 023 726 139  
Set in a stylish villa, Living Room has healthy salads and snack plates, plus a great coffee menu. Has a kid's playroom and baby changeroom. Uses organic and fair trade produce. Open everyday from 7am to 8.30pm. **02 A/C**

**Café Yei**

170 Street 450, (near the Russian Market), Tel: 012 543 360  
Quiet, cosy café serving bistro-style western cuisine, with extensive range of coffees. Good pasta dishes, a wide selection of pannini and wraps and fabulous cheesecake make this an ideal spot to escape the bustle of the nearby Russian Market. Air-conditioned dining upstairs. Open every day from 8am to 5pm. **A/C**

**Corner 33**

33E2 Sothearos Blvd., Tel: 092 998 850  
First-floor café overlooking the Royal Palace. Asian & Western meals served for breakfast, lunch and dinner with a nice selection of wines, cocktails, smoothies, and coffees. Four computer terminals allow customers to surf while they chill. **A/C**

**Fizz**

42 Street, 178, Tel: 015 609 909  
Possibly the first authentic juice bar in town. An excellent range of original juices is on offer as well as some Khmer and Thai dishes. Also has coffee and ice cream.

**Java Café & Gallery**

56 Sihanouk Boulevard, Tel: 023 987 420  
Great coffees, salads, mix-and-match sandwiches and juices served in an elegant setting. The relaxed inside dining area has a small gallery attached to it. Open 7am to 10pm. **A/C**

**Java Tea Room**

Monument Books, 111 Norodom Blvd.  
Second outlet of the popular Java Café located in the rear of Monument Books. Has comfortable mismatched sofas and antique-look décor. A small lunch menu is available along with an extensive tea and coffee menu. **A/C**

**La Gourmandise Bleue Patisserie**

159 St 278, Tel: 023 994 019  
Delightful French patisserie with a touch of the middle-east, offering chocolates, macarons, pastries, baklava along with coffee and tea. The menu now includes breakfast, salad and couscous (order one day in advance). Open from 7am to 8pm. **02 A/C**

**Madeleine's Café & Bakery**

19 street 228, Tel: 012 988 432  
Bakery and restaurant offering a variety of baked goods, organic lunches and catering services. Open Monday to Saturday 8am to 5pm

**The Coffee Maker**

50 Sihanouk Blvd., Tel: 023 987 721  
Recently opened, modern café overlooking Hun Sen Park, serves coffee, juices and light refreshments. Already popular with middle-class Khmers, this is a great place to watch the early evening exercises.

**The Melting Pot**

168 Street 155, Tel: 092 223 301  
Cute, cosy café with Parisian owners located diagonally across from the Russian Market's NYEMO. Good coffee and lunch spot specialising in French crepes. Open 8am to 5.30pm.

**The Deli**

13 Street 178, Tel: 012 851 234  
Chic delicatessen, bakery and small restaurant serving excellent bread and pastries. Take-away menu includes sandwiches from US\$2.50 and salads from US\$3. Open from 6.30am to 10pm (closed Sundays). **A/C**

**Two Fish Gallery Studio**

2D Street 302, Tel: 016 368 700  
www.twofish-gallerycafe.com  
Gallery space, art & Chinese calligraphy classes, reflective meeting space, private lunches and dinner parties, coffee and juices. Open 11am to 5pm (Closed Sunday & Monday). **A/C**

# K'NYAY

KHMER & VEGAN CUISINE

TUESDAY-FRIDAY 12-9PM  
SATURDAY 7AM-9PM  
SUNDAY 7AM-3PM

25K SURAMARIT BLVD.(ST.268)

023 225 225

www.KNYAY.COM

# TELL

RESTAURANT

A/C, PRIVAT ROOMS, GARDEN  
WESTERN DINNING SINCE 1999

# 13, STREET 90, BEHIND HOTEL LE ROYAL  
Phnom Penh, 023 430 650  
restaurant@tellphnompenh.com

# K'WEST

BRASSERIE BAR

## HAPPY HOUR

every day 6pm to 8pm

# Free wi-fi

## BRASSERIE BAR

Open every day  
6.30am to 12pm

1 Street 154, Sisowath Quay  
Phnom Penh :: Cambodia

cafés

**Art Café**

84 Street 108, Tel: 012 834 517  
Elegant bistro and art gallery in the style of an European coffee house that opened early January. German flame cakes and eau de vie as specialities. Open from 11am to 11pm. **A/C**

**Café Fresco I**

363 Sisowath Quay, Tel: 023 217 041  
This outlet at the base of the FCC sells strong Illy coffee and mix-and-match sandwiches. The interior has a slight retro 70s feel to it and there is a pleasant outside seating area. Open 8am to 8pm. **A/C**

**Café Fresco II**

Chr. Streets 51 & 306, Tel: 023 224 891  
Second outlet of the popular riverside café is in BKK. Has a similar feel and menu to its fore-runner including the same excellent coffee. Open 7am to 7pm. **A/C**

**Café Fresco III**

58 Street 53, Tel: 023 214 984  
The third outlet on the chain has the same mix of sandwiches, cakes, coffee and smoothies is close to the Central Market, making an ideal location to take a break from all that shopping. Open 7am to 6pm. **A/C**

# bar stool

## It's Better On Top

They may be a hike to get to, but several of Phnom Penh's rooftop bars and restaurants are definitely worth it for both the food and the views. Nora Lindstrom gets the bird's eye view.



**Tamarind**

### ■ TAMARIND

*Street 240*

A long-time favourite of expats and tourists alike, once you have climbed three flights of stairs, Tamarind's roof terrace offers an evening retreat from the Penh. Lounge around low tables on cosy pillows subtly screened off by thin curtains, or opt for more traditional seating at the tables closer to the street below. While the view is not breathtaking, the sky is beautiful at dusk and the restaurant is enclosed enough to keep the cold breezes out. Unfortunately the rooftop does not open until 6pm, meaning the pillows aren't available for lazy afternoons sipping happy hour cocktails. Open 6pm-11pm.



**The Place**

### ■ THE PLACE

*Sihanouk Boulevard*

Easily the poshest of Phnom Penh's rooftop bars, The Place also scores top points for its view. From up on the ninth floor, the capital spreads out below in all four directions as far as the eye can see. The view is especially spectacular in the evening when the Independence Monument is lit up and you can see the park beyond stretching almost all the way to the river. An enclosed rooftop bar is surrounded by outdoor tables and sofas. During the day, a tiny pool and sun loungers are available for use by gym members. Almost inevitably the drinks are not cheap – a can of coke is



**Chow**

US\$3.50 and a Tiger US\$4.50, while the cocktails are slightly better value at US\$6 – but the view of Independence Monument lit up at night is worth it. Open 5pm to 2am.

**CHOW**

*277 Sisowath Quay*

Skip the downstairs bar at Chow and head straight for the lift. The rooftop here makes for the perfect sunset venue. The view of the Tonle Sap is great and the happy hour drinks (between 4pm-8pm) are amazing value for money. The ambience is classy but fun. During the day, enjoy lunch (US\$8) and brunch (US\$7) menu deals whilst sheltering from the sun under the canopies. The only downside is the lack of proper lighting during the evenings – particularly if you want to have a good look at your food before venturing further. The rooftop also features sun loungers and a Jacuzzi,

mainly for the use of hotel guests though. Open 10am-11pm.

**MASTER SUKI SOUP**

*Sorya Centre*

Many are fooled into thinking the view from the skating rink at Sorya Mall is as good as it gets. In fact, by taking the lift a few floors further up to the dome of Master Suki Soup, the view becomes even more spectacular as the city sprawls out below. The soup is cheap and tasty too, however during the cold season the breeze can be a bit too reminiscent of ‘summers’ back home. With a lift going all the way up, the place is worth a visit even during a shopping trip to the mall, particularly for the unparalleled view over Central Market.

**NATURE & SEA**

*Corner of St 51 and St 278*

Located just opposite Wat Lanka, little Nature & Sea might go com-



Sorya Centre

លីក្វីដូ

# LIQVIO

Drop in and shoot some pool on our quality, slate 9 ball pool table!  
 Open 8:00am til late • Happy Hour 5pm-8pm. Angkor draft: 75c, Cocktails \$2.50  
 3B Street 278 • Tel: 023 720 157

9

4

14



FCC

pletely unnoticed by the average backpacker staying on the Golden Mile. However, this vegetarian-friendly and health-conscious eatery is worth the hike to the top floor of the building. Tasty crepes and galettes (from 11,000 riel) as well as inventively combined shakes (around US\$2) are house specialties. All food is free of MSG, preservatives and chemical additives. Where feasible, the ingredients are organically sourced. The view is not stunning, but the cushioned balcony is perfect for whiling away an afternoon. Open 8am-10pm.

#### ■ FCC

363 Sisowath Quay

The view from the FCC rooftop is iconic. Ahead is the Tonle Sap, along the riverfront to the right is the King's balcony, while the rest of the riverfront spreads

to the left. During national festivities, fireworks are often launched from the opposite bank of the Tonle Sap, giving FCC patrons best seats for the spectacle, but alas also the associated loud bangs. It's a lovely spot at dusk, though be warned, on warm nights seats right on the ledge are much in demand. The rooftop bar is open 4pm-11pm, though the area can also be accessed during the day.

#### ■ PACHARAN

389 Sisowath Quay

The F's Iberian younger sister has if anything better views than its more famed partner. Although the balcony is narrow, it affords views of the confluence of three rivers – the Tonle, Mekong and Bassac. The ideal spot for drinking a glass of cava or four, espe-

cially during the half-price happy hour (4.30pm to 7.30pm), check out the special offers. Currently free tapas accompany every glass of wine, although unfortunately not during the happy hour.

#### ■ VAN'S

5 Street 102

The rooftop at Van's is essentially an enlarged balcony, but what a balcony! Overlooking the post office, high chairs are placed along the balustrades while the red-tiled roof of this gorgeous colonial building provides a beautiful backdrop. In the middle, there is a small bar with an indoor-lounging area. The space is ideal for private parties, but regular punters should not overlook this top-end venue – especially during the 5pm-7pm happy hour when cocktails (US\$4) are two for one.

Opens 5.30pm, closing hours depend on custom.

#### ■ META HOUSE

6 Street 264

If you're into films, especially artsy ones and documentaries, Meta House is the place to go. With almost daily screenings of films (not Monday) on topical issues, free of charge, this lovely rooftop is one of its kind, and certainly the only one in the capital with real movie seats. The view which includes a few temple spires is not breathtaking, but that's not really why you came anyway. The bar stocks all the usual suspects, and nibbles, including sausage and baguette (not too different from a hot dog really), are available all night long. Don't be afraid to come at 6pm to enjoy the sunset. 🍷



www.harleycambodia.com  
Tel: 012 385 157

Talkin  
to a  
stranger

Don't drink someone  
else's Beer

Drink ours...  
in the garden!



South Australia's Own.



# bar stool guide

## key to symbols

- A/C** Air Conditioning
- WiFi** Free Wireless Internet Service
-  Tiger Super Cold
-  Live Music and DJs

**Cadillac Bar & Grill**  
 219E Sisowath Quay,  
 Tel: 011 713 567  
 Air-conditioned riverfront bar which promises a hassle-free drink. Mixing up burgers, pasta and some Asian food with Blues and rock and roll, this American-style bar serves good hearty food. Open 8am to 1am. **A/C**

**Cathouse Tavern**  
 4 Street 51  
 The longest standing of Phnom Penh's bars, which was the only bar in town during the U.N. days. The large curved bar invites you to sit and chat with the welcoming barstaff. Open 4pm to midnight. **A/C**

**Chow**  
 277 Sisowath Quay,  
 Tel: 023 224 894  
 Contemporary and sophisticated riverfront restaurant that serves southeast Asian cuisine, a wide range of cocktails, juices and lily coffee. Great place to have a drink during its half-price 4pm to 8pm happy hour. Open 7am to 11pm. **A/C**

**Diplomat's Bar**  
 69 Street 566,  
 Tel: 017 456 116  
 Set in a beautiful 1960s wooden Khmer house directly above Sarika Restaurant, the Diplomat's Bar exudes the elegance of Asian colonial times, yet has a refreshingly chilled out atmosphere. Has two VIP rooms and live music is played Thursdays to Sundays from 7pm to 11pm. **A/C**

**Dodo Rhum House**  
 42C Street 178,  
 Tel: 012 549 373  
 Bar named after an extinct bird, which is brave considering the turnover rate in town. Nicely decorated with strong, wooden bar and chill-out room at the back. Has a good specials menu and tapas as well as over 20 different flavoured rums created by bar's owner. Open 5pm to late.

**Elephant Bar**  
 Raffles Hotel Le Royal, Street 92  
 Tel: 023 981 888  
 Pleasant bar, popular with expats especially during the two-for-one happy hours (4pm to 8pm). A flamboyant carpet, comfortable wicker chairs and hotel

pianist provide a sense of a time gone by. Has many signature cocktails, including its more illustrious sister hotel's trademark Singapore Sling. (Open 2pm to 12am Monday to Friday & 12pm to 12am Saturday & Sunday). **A/C**

**Elsewhere**  
 175 Street 51,  
 Tel: 023 211 348  
 A beautiful garden with palm trees, a bath-sized swimming pool and luxurious reclining couches makes you feel anywhere else than in the centre of town. Great jazz-funk and ambient soundtracks make this the optimum place to chill. Has Friday night parties once a month with DJ and a good clothes shop upstairs. Closed Tuesdays.

**Etcaetera Bar**  
 38 Street 118,  
 Tel: 092 538 385  
 Classic, small, black bar owned by Memphis owner, Bona Thiem has a large range of cocktails and daily specials. True to Memphis tradition, live music is played every Sunday night from 8pm to 11pm. Happy hour is 5pm to 8pm. Open from 10am to late, closed Mondays. **A/C**

**Equinox**  
 3A Street 278,  
 Tel: 012 586 139  
 Cool French hang-out that overlooks Street 278. Upstairs bar has a nice open balcony, good cocktails and music. Has the best football table in town with regular tournaments. Also has a second street-level bar. Open 10:30am to late. **A/C**

**Factory Lounge**  
 83 Street 240  
 French-run bar with eclectic paintings and good range of cocktails. Good place to chill after shopping along the street. Open 5pm to late.

**FCC Phnom Penh**  
 363 Sisowath Quay,  
 Tel: 023 724 014  
 The first stop for newcomers and it's easy to see why. Set in a beautiful colonial house with sumptuous views across the river on one side and the National Museum to the other. It's best to come at sunset when the streets below are most crowded, the cocktails are half price and draft beer goes for US\$1. Open 7am to midnight. **A/C**



#33 Level 1, Level 2, Sothearos Blvd (Corner St. 178), Phnom Penh, Tel.: 092 998 850, Email: info@corner33.com

**CORNER 33**

## Café and Lounge

Level 1, Open from 7am-10pm

*Relaxing Spacious Modern*

- Great Food
- Great Coffees & Drinks
- Great Service
- Great View
- Free Wifi & Internet Stations





**BAR 33**  
 Level 2, Open from 5pm...

One level up from Corner 33 Café, Bar 33 is an exciting new bar overlooking the Royal Palace. Come and enjoy a night of great company over a popular selection of drinks and a fabulous view to match...  
**Happy Hour 5pm-8pm daily!**

# Green Vespa

## Open from 6.30 am



### Roast every Weekend

**Sirloin of Beef**  
**Rack of Lamb**  
**Leg of Pork and Crackling**  
**Weekend Newspapers**  
**The Times, Sunday Times**  
**Irish Independent**  
**Glasgow Herald**  
**Scotland on Sunday**  
**Great British and Irish**  
**Pub and Restaurant**

**ENGLISH PUB  
& RESTAURANT**

*The Rising Sun*

Great British Food  
Served All Day.

Good Music,  
Great Mixed Drinks,  
& Some of the  
Coldest Beer in Town!

#20 Street 178 Tel: 012 970 718  
Phnom Penh, Cambodia

Open from 7am!

I see fed people

*Flavour* Restaurant

Drop in to Flavours - everyone's favourite restaurant, café & bar  
Corner street 51 (Pasteur) & Street 278

## Blind Date



AsiaLIFE is hosting the first Blind Date Games Show  
Wednesday, Feb. 11 from 8pm at Talkin to a Stranger

Fabulous prizes for contestants provided by Quarto Productions  
and Thalias. There will also be prizes for the audience.

If you think you've got what it takes to be a contestant,  
contact Derek or Wendy behind the bar at Talkin to a Stranger.



## Bar Talk: Jaan



"WE HAD ENOUGH FAMILY members to run the places so we decided to open one more," says Pascal Plamondon about his latest venture "Jaan" on Sisowath Quay. That's as good a business plan as any other. The other two businesses in his empire are the restaurant Flavours and the bar Liquid, both located in street 278. But because of its location – on the riverside and right next to the night market – Jaan is much more tourism-oriented than Flavours and Liquid.

"My background is marketing, I'm not a Chef, I can't cook anything," the forty year-old Quebecois admits. What do you do in such a case? You marry. "My wife is pretty good at cooking but she's too busy to run all three kitchens so she's managing them."

With its strategic positioning at the corner of Sisowath Quay and Street 106, Jaan is a great spot to watch the street-life flow by sitting on its terrace while having one of their breakfasts (\$3 to \$5.75), ranging from omelettes to eggs Benedict to the classic English, American and European. "Basically what we do is we look for a good location to open up a place, like Wat Lanka. When I first opened Flavours there was nothing there, so I was very successful from day one."

Despite a slow start which Pascal blames on the overall economic slowdown and the recent troubles in Thailand, Jaan certainly has the potential to become another

success story. "We put a lot of money into it and tried to make it the best quality we could. I think we've done a good job but it took a long time to build," he says.

The Canadian is not a newcomer in the Kingdom, he has been in Cambodia for more than ten years now. After a Cambodian-Canadian friend of his asked him to come and run a hotel, Pascal met his wife Srei Oun and has been here ever since. Despite having worked in restaurants all of his life, Pascal says he's not a professional. His real background is in telecommunications. "I just did regular jobs in restaurants, but with my marketing background I have a bit of a flair for people, and locations."

All of his ventures are managed entirely by his family members. Are there any left to run any future projects?

"I'd like to do something bigger, to offer some 'experience', for example live music," he says. "It could be a band, it could be a mini-musical, like some of these places in Bangkok." But according to him the talent is difficult to find here. "My point of view is entertainment, more than food. It's the way to go, I'm very North-American, you know," he laughs. Be warned though – watch out for the new Crazy Horse, coming your way soon.

*Jaan, corner of Sisowath Quay and Street 106. Open breakfast, lunch and dinner. - JOHAN SMITS. 📍*

**Flavours**

*Cnr. Street 51 & 278,  
Tel: 012 175 896*

Relaxing restaurant and popular bar run by two Quebecois with comfortable chairs that fall out onto the street. The mix of Asian and western cuisine has proved so popular that they have a copycat restaurant opposite. Open 7am to late.

**Freebird**

*69 Street 240,  
Tel: 023 224 712*

Air-conditioned American bar with neon lighting, a variety of memorabilia, comfortable seats, rock music. The menu is international with good lunch offers and an excellent range of bottled sauces. Be prepared for some good solid R&R. WiFi is available, but there is a charge. Open 7am to midnight. **A/C**

**Gasolina**

*56/58 Street 57,  
Tel: 012 373 009*

The largest garden bar in town. Extensive menu includes a Saturday brunch and BBQ, and Sunday brunch with crêche facilities. Open from 11am to 8am.

**Green Vespa**

*95 Sisowath Quay,  
Tel: 012 887 228*

The walls of this popular expat haunt are strewn with photos of vespas and VIPs. Has an excellent selection of single malt whisky, and does a US\$10 special combination of food and drink. Good music, especially if you are an 80s throwback. Open early till late. **A/C**

**Gym Bar**

*42 Street 178,  
Tel: 012 815 884*

The best sports bar in town with more wide screens than sense and a good nine-ball pool table to boot. Ideal for watching Premiership football or any other sport. The food is good and there's a non-sports quiz every Tuesday. Open 11am to late. **A/C**

**Hope and Anchor**

*213 Sisowath Quay,  
Tel: 023 991 190*

Well-located restaurant and bar on the front with seats stretching out onto the street. Wide screen TV for watching football. Open 6am to 2am.

**Howie's Bar**

*32 Street 51*

Air-conditioned and open until very late, this is the Heart's unofficial chill-out bar although the sound system could give the Heart a run for its money. Tends to be a popular late hang-out, especially around the pool table. Open 7pm to 6am. **A/C**

**Huxleys**

*Cnr. of Streets 136 & 5,  
Tel: 023 986 602*

The wood-panelled interior decorated with posters of famous British screen personalities and sportspeople helps to create the atmosphere of a Covent Garden bar. Well-stocked bar with fantastic cocktails. Not to be missed. **A/C**

**K West**

*1 Street 154 (Cnr. Sisowath Quay)  
Tel: 023 214 747*

Air-conditioned bar and restaurant with a good value happy hour from 6pm to 8pm Fridays. Renowned for excellent mojitos. Open 6.30am to midnight. **A/C**

**Liquid**

*Street 278,  
Tel: 012 765 896*

Welcoming Metroesque bar on the popular Street 278 run by the same owner as Flavours. Serves food and good cocktails. Has one of the best pool tables in town. Happy Hour from 5pm – 8pm. **A/C**

**Maxine's**

*Over Japanese Bridge, Tel: 012 200 617*

Stirringly eclectic bar right on the river, boasting the best sunset views in Cambodia. Across the Japanese Bridge, Maxine's – or Snow's Bar – is well worth seeking out for its laid back ambience and old Indochine charm. Open Tuesday to Sunday from near sunset til late. **A/C**

**Memphis Pub**

*3 Street 118,  
Tel: 012 871 263*

The only permanent rock venue in town with a house band that plays covers with Filipino singers. Band plays from 9pm to 12.30am (weekdays) and 10pm to 2am (weekends) and guests are always welcome to join in. Also has open mike sessions. Open 5pm to late, closed Sundays. **A/C**

**Meta House**

*6 Street 264,  
Tel: 012 607 465*

This multi-media arts centre established by German Nico Mesterham opened in January. Has a very cool terrace bar with barbecue. Closed Mondays.

**Metro Café**

*Cnr. Sisowath Quay & Street 148.  
Tel: 023 222 275*

Stylish and swish, Metro has much more than a cool décor and changing light boxes. Reasonably priced Tiger and house wines and a great range of Martinis, try the Espresso. Open 10am to 2am. **A/C**

**One More Pub**

*16E Street 294,  
Tel: 017 327 378*

English-style bar with comfortable wooden bar stools, filled with traditional paraphernalia and enough flags to make the UN envious. No hip hop nor techno music, instead hearty Teutonic fare. Has elegant, terracotta-tiled terrace and four guest rooms upstairs (US\$22 to US\$30). Open from 5pm to late, happy hour from 5pm to 7pm, closed Tuesdays. **A/C**

**Open Wine**

*219 Street 19,  
Tel: 023 223 527*

Large wine shop with well-priced wines from around the world. Has an outside dining area with occasional wine tastings. Open from 9am to 11pm every day. **A/C**

**Pacharan**

*389 Sisowath Quay,  
Tel: 023 224 394*

Barcelona comes to Phnom Penh via London's Mayfair in this exquisitely up-market bodega. Specialising in tapas and fine Spanish wines, this air-conditioned restaurant and bar is set in a beautiful colonial building with great decoration, an open kitchen and sweeping views of the river. Open from 11am to 11pm. **A/C**

**Pickled Parrot**

*4-6 Street 104,  
Tel: 012 633 779*

Air-conditioned bar with excellent 9-ball pool table, that's a popular late night hang-out with expats. Reliable international cuisine is available at the bar, free internet and 24-hour cable sports channels. Clean well-kept guesthouse upstairs with 15 rooms. Open 24 hours. **A/C**

**Pontoon Lounge**

*River end, Street 108,  
Tel: 012 889 175*

Phnom Penh's only floating bar, stylish, funky drinking spot and late night venue. Favourite among the expat scene, Pontoon sometimes hosts party nights with visiting DJs. The friendly staff mix excellent cocktails at the beautiful amber bar. Unbeatable location. Open 11.30am until midnight (weekdays) and until late at the weekend.

**Revolution**

*96 Street 51, Tel: 012 393 392*

Poker Mondays, GLBT encouraged. Cheeky cocktails and shooters. Pool table. Live music & open mic Thursdays and Saturdays. Happy hour 4pm – 8pm. Open 7 days a week 7am to late. **A/C**

**Rising Sun**

*20 Street 178, Tel: 012 970 719*

English-style pub with reliable breakfast, meat pies and hamburgers. Has a regular following around the bar at night especially on Fridays. Great posters of British films and TV classics adorn the walls. Ideal for that touch of nostalgia



# HUXLEY'S

## Public House

**Classic British Pub Grub**

**Happy Hour**  
Buy One Get One Free  
Mon – Fri 2-4pm & 8-10pm on  
all House Spirits & Cocktails

**Roast**  
Every Sunday

www.huxleys.biz • e-mail@huxleys.biz • Corner of St. 136 & St. 5 • Tel: 023 986 602

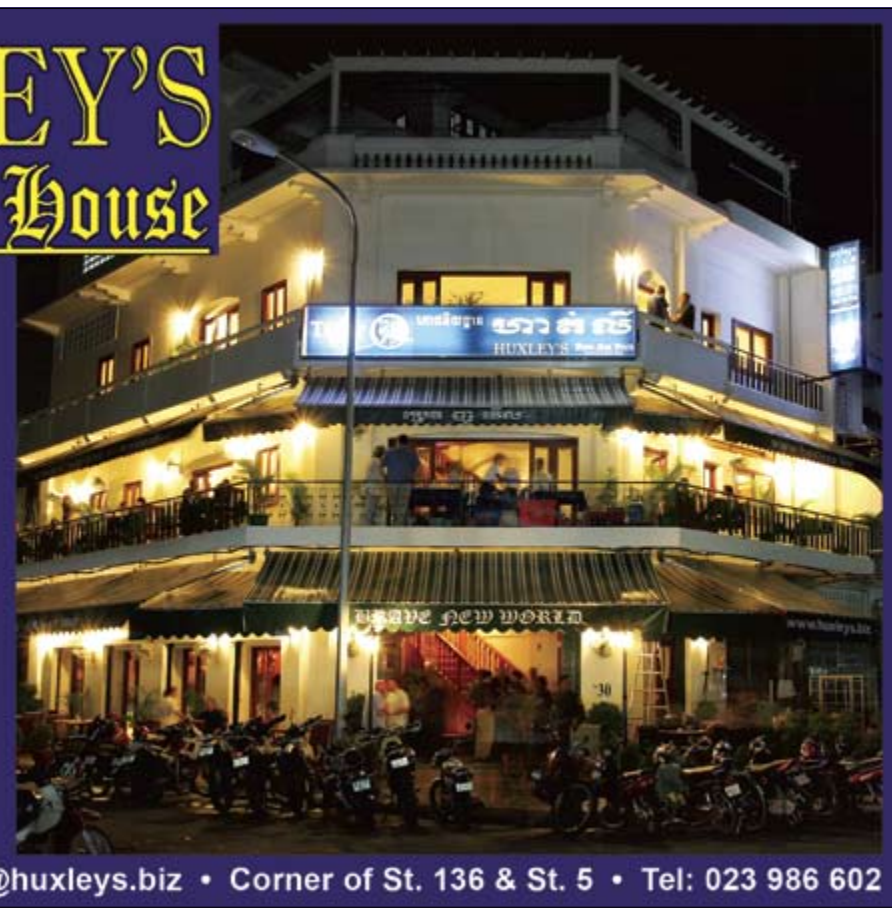

# Grapevine: Beyond Bordeaux

For some wine drinkers, European wines begin and end at Bordeaux, which is a great pity, as there are a host of great wines from all over Europe that are readily available here in Cambodia and – unlike many Bordeaux – they won't break the bank.



## ■ CHAPOUTIER BILA HAUT, OCCULTUM LAPIDEM, 2005

One of the most prestigious names in all the Rhone Valley, Chapoutier has expanding its operations to take in vineyards in Roussillon and even Australia. The Bila Haut Estate in Roussillon has three grape varieties – Grenache and Carignan, known for their ripe fruity characteristics; and Syrah, known for its finesse, structure and spicy finish.

This full-bodied wine combines the terroir, generosity and warmth of the Roussillon region with the skill of winemaker Michel Chapoutier. The aromas are complex, offering up five spice, coffee grinds and ground pepper. On the palate the wine is full-bodied yet elegant, with the rich flavour of black cherries balanced by mocha, spice and tobacco leaves. A wonderfully affordable wine, it has been produced by one of France's very best winemakers at the top of his game. Serve with something, or someone, wild.

## ■ VILLA TRASQUA, CHIANTI RESERVA, 2005

A Tuscan Estate with big ambitions and the ability to achieve their aims, perhaps Villa Trasqua's greatest coup has been to harness the services of the legendary Tuscan winemaker and viticulturist

Stefano Chioccioli. One of the most revered and regarded winemakers in the region, he was the first Italian winemaker to receive the prestigious 100 out of 100 point ranking for an Italian wine by wine critic Robert Parker.

The Chianti Reserve (made from 100 percent Sangiovese) is matured in oak for a full-year longer than the standard (also very good) offering. Deep ruby in colour, the wine is infused with aromas of aniseed, violets, spiced fruits and cherry oak. The palate shows a medium-bodied wine with the intense flavours of red fruits and mixed peel, given further complexity by hints of semi-dried tomato, aniseed and oak spice. Its lively acidity gives the wine structure, demanding it be matched with rich, hardy Italian food.

## ■ TORRES, CORONAS, 2004

Spanish wines are undergoing a global resurgence in popularity at the moment. New vineyard management and winemaking techniques are producing some excellent wines. There is no bigger name in Spanish wine than Torres, the family has been involved in the Spanish wine industry for over three centuries.

The Torres Coronas is made with the traditional Spanish red variety of Tempranillo,

(known locally in Catalunya as 'hare's eye') and given a splash of Cabernet Sauvignon. The wine has a deep, opaque red colour with aromas of wild strawberry, blackberry, oak spice and truffles. On the palate the wine is full-bodied with powerful flavours of wild berries and oak spice, and complex hints of raw meat, iron filings and gunsmoke. The tannins are ripe and persistent, the finish savoury and long. Match with fermented, spiced meats, continental sausages, rack of lamb, or a choice steak.

## ■ MONT REDON, CHATEAUNEUF DU PAPE, 2003

I've always been a huge fan of the best wines from the Rhone Valley, where as an industry veteran once quipped to me, "You get the bouquet of a Burgundy and the body of a Bordeaux at around a tenth of the price of either." The Via Antiqua – the old Roman route to northern Gaul – once wound its way through the ancient vineyards of Châteauneuf-du-Pape. Near its history-strewn path lay what are now the vineyards of Château Mont-Redon. The first mention of this vineyard appears in 1334.

The wine is a typically complex regional blend of Grenache, Syrah, Cinsault,

Mourvedre, Counoise, Muscardin and Vaccarese. The aromas offer cherries and red berries. On the palate are sour cherries and other red fruits, sweet spices and a hint of black coffee. Full of flavour and very balanced – not tiring or over the top as some other wines from this region – this is a wine to sit back and really enjoy, just a lovely drink on its own or to match with beef or game.

*Darren Gall is a 20-year veteran of the wine industry with experience from brand ambassador to winemaking and grape growing. He has worked in over 20 countries and is currently based in Asia as a market consultant. You can contact him at: [darren\\_gall@yahoo.com](mailto:darren_gall@yahoo.com)*



## THE WINKING FROG

Live Sport • Live Music • Hotel



Thai and  
Western Food

FRIDAYS 8 PM till LATE  
Live Band

SATURDAY 8 PM till LATE  
Live Band & Karaoke

Sothearos Blvd., Phnom Penh, Cambodia • Tel: 023 356 399 • 013 356 399 • 099 801 548



[www.thewinkingfrog.com](http://www.thewinkingfrog.com)

and the fish and chips are good, although not wrapped in newspaper. Open 7am to 10pm.

**Riverhouse Lounge**  
6 Street 110, Tel: 023 220 180  
Set above a sophisticated restaurant, the Lounge has become the alternative dance venue for both expats and young Khmers, its key advantage is its location, with a self-contained air-conditioned dance room and great balcony to chill out and watch the river float by. Actually varies its music, featuring some of the best DJs in town. Monday night is Retro, Thursday is House and Hip-hop is on Tuesday & Friday. Open 4pm to 2am. **A/C** 🍸

**Rory's Irish Pub**  
33 Street 178,  
Tel: 012 425 702  
Most Irish of the Irish bars in town with the barmaids dressed in emerald green. Good place to talk to local expats or try the Irish stew. Open 7am to midnight or 2am at weekends.

**Rubies**  
Chr. Street 19 & 240,  
Tel: 012 823 962  
Small corner wine bar with warm wood panelled interior and loyal following. Happy Hour from 5.30pm to 7.30pm. Open 5.30pm til late, closed Mondays.

**Salt Lounge**  
217 Street 136  
In addition to being Phnom Penh's first openly 'gay' bar, has probably the most contemporary design in town. It also welcomes straight customers. Open 6pm to late. **A/C**

**Saffron**  
11 Street 278, Tel: 012 247 832  
Pakistani and Middle Eastern café, restaurant and wine bar. The curries are excellent and not too spicy, and come with a range of breads and chutneys. The wines have a bias towards the antipodes, including possibly the best range of wines by the glass in town. Open 11am to 11pm. **A/C** 🍷

**Scoop Bistro Bar**  
2-6A Regency Square, Mao Tse Tung Blvd., Tel: 023 216 130  
Elegant, chic bistro with a simple, yet refined black and white design with comfortable, high-backed dining chairs providing seclusion from other diners. Slightly raised lounge area is ideal for cocktail or coffee. Has three private rooms. Open from 11.30am to midnight, closed Sundays, reservations recommended. **A/C** 🍷

**Sharky Bar**  
126 Street 130, Tel: 023 211 825  
Biggest and most famous of Phnom Penh's bars is set on the first floor with countless pool tables and a large balcony to look out over the street. Guaranteed to be lively, a place where anything can happen. Serves surprisingly good food, especially the Mexican. Open 4pm to 2am. **A/C** 🍸

**Talkin to a Stranger**  
21B Street 294  
Elegant bar with nice gardens set in the

heart of NGO town. Excellent place for post-work drinking or indulging in their vast array of cocktails. Good food and one of the few places in town putting on events and live music. Has a trivia quiz every second Tuesday. Don't be a stranger. Open 5pm to late, closed on Mondays. 🍸

**Velkommen Inn**  
23 Street 104,  
Tel: 092 177 710  
This comfortable hotel restaurant and bar, just off the riverfront, offers a wide selection of western dishes as well as several Scandinavian specialities with a full bar, draught beer, wine and sprits. Open 7am till late. **A/C** 🍷

**Walkabout**  
109 Street 51,  
Tel: 023 211 715  
If nowhere else is open in town then you can always depend on the Walkabout. Plenty of women to offer males some company, but if you find yourself here then you should really be thinking it's time to go to bed. Open 24 hours. 🍷

**The Winking Frog**  
128 Sotheaors Blvd.  
Tel: 023 356 399  
Large air con British-run pub with live band and DJs at weekends. Thai Chef preparing pub grub, Thai and Khmer food and large slate, 9-ball pool table at the back, this place offers something for everyone. Has a 31-room guesthouse upstairs. Open 24 hours. **A/C** 🍷 🍸

**Zeppelin Bar**  
109C Street 51,  
Tel: 012 881 181  
If you like your music heavy then this is the bar for you. Over 1,000 vinyl albums played by stone-faced DJ owner. New location is next to Walkabout. Unique for Phnom Penh. Open 4pm to late. 🍷

**Nightclubs**

**Heart of Darkness**  
38 Street 51  
The most famous of the city's nightspots with a good-sized dance floor make this the in-place in town. Has well priced spirits and mixers and is totally packed out on Friday and Saturday nights. Open 8pm to late. **A/C**

**Riverhouse Lounge**  
6 Street 110,  
Tel: 023 220 180  
The alternative dance venue for both expats and young Khmers. Self-contained air-con dance room and great balcony to chill out. Monday night is Retro, Thursday is House and Hip hop is on Tuesday and Friday. Open 4pm to 2am. **A/C** 🍸

**DJs**

**DJ Paul Stewart**  
Tel: 017 362 849  
English DJ entertainer, presenter and show director who has years of experience in many countries. 🎧



*Fine Wine Boutique & Tasting Gallery*

1580 - 1780  
Street 240  
Phnom Penh  
Cambodia  
023 990 951



**MAKE THE RIGHT CONNECTIONS M-STYLE**

- Connections
- Support
- News
- Lifestyle
- Health
- Entertainment
- Network

www.mstylekhmer.com

# scrapbook



@CHOW



@Gasolina



@Gym Bar



@Chinese House



@Pontoon



@Pontoon



@Gasolina



@Chinese House



@Chinese House

## HISTORY



## ELEGANCE



## COMFORT



## ALONG THE SEA SHORE



The Independence Hotel  
● Boutique Resort ●

Street 2 Thnou, Sangkat No. 03, Khan Mittapheap, Sihanoukville, Cambodia  
Tel: +855-34 934 300 - 303 H/P: 012 728 090 • Fax: +855-34 933 660  
Web: [www.independencehotel.net](http://www.independencehotel.net)  
Email: [info@independencehotel.net](mailto:info@independencehotel.net) or [indph@online.com.kh](mailto:indph@online.com.kh)

# kaleidoscope

## Hip hop in da room

Phnom Penh's latest international hip hop event shook Pontoon in early January. **Nora Lindstrom** had a chat with the artists, **Akil** the MC and rapper **Hydro Phonics**.



Kicken' it with Akil

“THIS IS HIP HOP YOU-know-what-I’m-saying” shouts Akil the MC, of 90s hip hop band Jurassic 5 fame, with an L.A. twang to the enthusiastic and expecting crowd at Pontoon. The float is packed to the rim and there are jokes about the place sinking – again. Thankfully all that disturbs the night of international and local hip hop are sporadic power cuts. Even these only elicit cheers from the audience as well as break dancing to the beat of claps.

### ■ STATE OF THE ART

Akil is one part of the Bangkok-based band 4dub, together with rapper Hydro Phonics. The MCs first time in Cambodia, he is both surprised and impressed, especially after a visit to the hip hop NGO, Tiny Toones.

“It’s good to see hip hop in its purest form here,” he says. “It’s not commercial, and it’s not just rap.”

Cambodia’s hip hop artists have gone back to the roots of the art, instead of following the often aggressive but popular style of gangster rap, feels Akil. “Their music is not Asian at all,” he says. “It’s pure, almost soulful, like old blues.”

Inspired by beats, social conditions, and little things someone might say, hip hop is an outlet for expression, a way of telling a story or sending a message, says Akil.

Hydro has the same aversion to commercial gangster rap as his partner. “Hip hop is holistic, it’s about graffiti, breakdancing ... it’s about creativity,” he claims. Despite being a rapper himself he wears a t-shirt stating “Rap is only one element of hip hop.”

### ■ THE NICE FACE OF HIP HOP

Though they may look fierce in posters, in person both men are rather charming. Nor are they desperate for the limelight. For the Pontoon gig, they opened the stage for Cambodian hip hoppers by including teenagers from Tiny Toones as well as the Klap Ya Handz collective.

“We are involved in this thing called ‘skill districts,’” explains Akil. “The project aims to open networking channels linking people involved in hip hop and highlighting artists who might otherwise go unnoticed. Now Cambodia is a part of it too.”

The duo’s good deeds don’t end there. They have begun work on a charity song to raise money for the victims of a nightclub fire in Bangkok on New Year’s Eve.

“The club didn’t have insurance, so many of the victims

will get no compensation,” they explain, adding that many Thai-based artists are contributing to the project.

Although he admits to occasionally missing Jurassic 5, the group that was a major part of the alternative hip hop scene in the early 90s, Akil is not dwelling on his past fame. “Life goes on, I get to do a lot of things now that I wouldn’t have been able to with them,” he says. “Also, I can spend more time with my family – I have three teenage sons and a 9-year-old daughter back in LA.” Naturally, they are into hip hop too.

Both Akil and Hydro hope to return to Cambodia in the near future, although they also have an album coming out in the Spring to work on, as well as both a Hollywood and a Thai action film to feature in. ■





## Bootleg

AsiaLIFE takes a look at some of the DVDs available in a shop, or stall, near you.

### ■ GRAN TORINO

(2008, *Clint Eastwood*)

At first glance, *Gran Torino* seems much like many other Clint films: gun-toting, bigoted widower Walt Kowalski (Eastwood) ekes out a lonely existence in a neighborhood that has been almost taken over by Hmong immigrants until local gangsters provoke his squinting ire. Yet the film unfolds as a drama in its truest sense: touching, funny and sad in almost equal measure. Emotionally rich without sentimentality, two-time Oscar winner Eastwood, now 78, has crafted another layered masterpiece that presents the human face of a prickly, unloved Korean War veteran with very few low notes. Recommended.

### ■ ROCK AND ROLLA

(2008, *Guy Ritchie*)

Hailed as an innovator for *Lock Stock* and again less-so for the strikingly similar *Snatch*, with his follow up to the regrettable *Revolver*, Ritchie has truly proven himself as a one trick pony. The rambling excuse for a script stinks so badly it could have been written on used toilet paper. This film was never going to be a classic.

But atrocious acting and a plot more convoluted than spaghetti junction lowers the quality from poor to dire. The one-dimensional gangsters are about as scary as the fake Richie himself, an embarrassed aristocrat who was brought up by a baronet. Terrible.

### ■ THE ITALIAN JOB

(*Peter Collinson, 1969*)

Now tainted by association to the Mark Wahlberg infected 2003 remake, the original *Italian Job* holds a special place in all British hearts. Boasting a Quincy Jones soundtrack that's good enough to sing along to and such stellar actors as Michael Caine and Noel Coward, this is the quintessential kitsch heist movie. Recently released from prison, Charlie Croker (Caine) must lead a rag-tag bunch of misfits and ne'er-do-wells to steal gold bullion from a Roman bank under the noses of the Mafia. A car aficionado's dream, the film features such classics as a Lamborghini Miura, an Aston Martin DB4 and Jaguar E-Types, and culminates in an unforgettable chase through a traffic-clogged Rome in three (old model) Mini Coopers. 📺



# Just Married!

In honour of the month of romance this month's exhibition at the French Cultural Centre features wedding photos throughout history collected from around the globe. Runs from Feb. 13.





**Cinemas**

**Le Cinema**

**French Cultural Centre**  
218 Street 184 Tel: 023 213 124  
100-seat cinema shows international art house and mainstream movies. Occasional films in English. Children's cinema on Saturday mornings at 10am.

**Meta House**

6 Street 264 Tel: 012 607 465  
Movie shorts and documentaries from Cambodia and the rest of Asia. All movies start at 7pm, closed Mondays.

**Galleries**

**Art Café**

84 Street 108 Tel: 012 834 517  
Elegant bistro and art gallery in the style of a European coffee house with rotating exhibitions. Music played Friday to Sunday. Open from 11am to 11pm.

**Café Living Room**

9 Street 306, Tel: 023 726 139  
Has regular exhibitions as well as art classes for adults and kids. Open every day from 7am to 8.30pm.

**Dori Thy Gallery**

9 Street 278 Tel: 012 661 552  
Features the black and white photographs of German photographer, Doris Boettcher is open from 10am to 6pm.

**French Cultural Centre**

218 Street 184 Tel: 023 213 124  
Large space in the grand floor of the cultural centre has changing exhibitions and hosts special talks and events.

**Happy Painting Gallery**

FCC; Cambodiana Hotel; Domestic Airport  
Open since 1995, these aircon art shops sell the colourful and positive works of iconic artist Stef. Accepts all major credit cards. Open from 8am to 10pm.

**Java Café & Gallery**

56 Sihanouk Blvd., Tel: 023 987 420  
www.javaarts.org  
Contemporary art gallery with regular exhibitions of Cambodian and international artists. Website has details about Cambodia's contemporary art scene.

**Meta House**

6 Street 264,  
Tel: 012 607 465  
Multimedia arts centre on three floors has regular exhibitions, interviews with filmmakers and short films, closed Mondays.

**Reyum**

47 Street 178, Tel: 023 217 149  
Small gallery with regular exhibitions of Cambodian artists. Part of an NGO established for preserving traditional and contemporary Cambodian arts.

**Two Fish Gallery Studio**

2D Street 302 Tel: 016 368 700  
Gallery space, art & Chinese calligraphy classes, reflective meeting space. Open 11am to 5pm (Closed Sunday & Monday).

**Performing Arts**

**Amrita Performing Arts**

Tel: 023 22 0424  
www.amritaperformingarts.org  
Performance art co. puts on contemporary, classical music, dance and theatre.

**Art & Foundation**

84 Street 108,  
Tel: 012 834 517  
www.amritaperformingarts.org  
Performing western and Classical Music

**Sovanna Phum Khmer Art Association**

111 Street 360,  
Tel: 023 987 564  
Theatre with performances of shadow puppetry, classical and masked dances every Friday and Saturday at 7.30pm. 

In the Picture



**PICTURES OF STORIES**, the latest photo exhibition by American artist Bradford Edwards, is currently on display at the FCC Phnom Penh throughout this month. Bradford, who prefers to call himself an artist and not a photographer makes a clear distinction between the two concepts.

Whereas a trained photographer works exclusively with the camera, Bradford sees an artist using the camera as his or her disposal. He confesses that he "shoots images constantly for different purposes" and the result can be seen through the twenty colourful images taken within the last two years in Cambodia and Vietnam.

For Bradford, the key purpose of this exhibition

is the telling of a story in the first person, via text. "The real basis for this series is not actually a visual idea, it's not the photographic images themselves that are the central focus – it's the story behind them," the artist explains. To him, the fundamental reason for taking a photograph is "primarily visceral and then verbal – classic storytelling."

Bradford has been dividing his time mainly between Cambodia and Vietnam over the past 14 years and feels that his life during that period has largely been defined by crossing the border at Moc Bai. "This new work is simply a record of that movement, the stuff of my life, the people and things that I run across," he states. 



**Discover the taste of Java's bakery, homemade and fresh every day!**

**Java Café & Gallery**

56e1 Sihanouk Blvd  
Phnom Penh, CAM  
7d/wk 7am - 10pm  
023 222 087

**Java Express**

56e1 Sihanouk Blvd  
Phnom Penh, CAM  
M - Sa 7am - 3pm  
092 289 126

**Java TeaRom**

At Monument Books  
111 Norodom Blvd  
Phnom Penh, CAM  
7d/wk 8am - 8pm  
092 451 462



# Arts Diary

## ■ OPENING THIS MONTH

### Portraits

American artist, Mark Pollock's current work is about people he has met, talisman that protect them and portable art objects. The exhibition opens at Meta House on Feb. 3 at 6pm and runs until Mar. 4.

### Little Things

A dual photographic exhibition on the innocence of childhood and the beauty of small objects by photographers Nicolas Le (Lenshot) and Emmanuel Maillard. Opens Feb. 6 at Equinox 7pm.

### Tribute to Svay Ken

An exhibition in tribute to the recently deceased Grandfather of Contemporary art in Cambodia. Opens Feb. 13 at 6pm at Java Café & Gallery and runs until Mar. 1

### Just Married!

The French Cultural Centre will exhibit a collection of over 1000 humorous, stunning and at times awe inspiring wedding photos from around the globe and throughout history. The exhibition begins on Feb. 21 at 6.30pm. The opening will be accompanied by a live wedding orchestra.

### Faces of Asia

Feb. 16 - Larry Snider's Photography exhibition opens on Feb. 16 at the Centre for Friends Without a Border, Siem Reap and runs until Apr. 30

### Works of Tim Page

Photographs by award winning English photographer Tim Page go on sale Feb. 24 at Meta House.

### Paintings by Khachao Touch

Art Café is holding an exhibition of paintings that transmute negative energy into positive energy of care and love. The opening begins at 7pm on Feb. 28

## ■ ONGOING

### Smile

A exhibition of photography by ten students from the Centre for Children's Happiness continues at K'Nyay. The Children's images of phnom Penh and its surroundings are also available for purchase in Calendar form for US\$10. All proceeds go toward CCH. The Show runs into March.

### Pictures of Stories

Bradford Edwards photographic exhibition continues at the FCC. The show comprised of 20 random yet meaningful photographs of images from Cambodia and Vietnam runs throughout the month of February.

### Visual Makers

Exhibition of the collective works of photo-agency Asia Motion continue at Equinox, runs through to Feb. 4.

### Photography Exhibition

By Louis Sclavis continues at the CCF Gallery and runs until Feb. 7

### Traits and Portraits of Women

Margherita des Balzo creates an homage to the brilliance and grace of women through drawings. Continues in the CCF Hall and runs until Feb. 7

## ■ MUSIC, EVENTS & PERFORMANCES

### Sounds of Berlin

DJ Derek Rysle, will spin a selection of underground club tunes from "Minimal to Electro" while the Meta House makers screen international video art at La Croisette on Feb. 7. Free Admission

### Age of Elegance

18th Century European flute music Featuring Baroque recorder player, Anina Paetzold from Berlin. The show at Art Café begins at 7pm on Feb.

### Wayang Golek (Malaysian Theatre)

Master Dalang Mr. Aneng Kiswanto performs Feb. 21 at 7pm at Art Cafe

## ■ FILM

### Rooftop Cinema

Each month the Meta House shows films, documentaries and hosts events on its rooftop terrace. Closed Mondays. This month's screenings include (7pm unless stated):  
**Feb. 1** - *Beyond the Land of Smiles*, followed by *Our Southern Home*; **Feb. 4** - *Zeit Geist - The Movie*; **Feb. 5** - *The Blues* (Clint Eastwood) followed by *Godfathers and Sons*; **Feb. 6** - *Until the Violence Stops* a documentary by the creator

of the *Vagina Monologues*, *Eve Ensler*; **Feb. 7** - *Cambodia Dreams* (Stanley Harper); **Feb. 8** - *Mekong - The Mother and When the Floods Recede*; **Feb. 10** - Live Tango Performance followed by Gotan Projects' *'La Revancha del Tango'*; **Feb. 11** - *Working Man's Death* (Michael Glawogger); **Feb. 12** - *Red Earth Village* - Dey Krohom captures the lives of the people who lived in and were violently evicted last month from the last slum community in central Phnom Penh; **Feb 13** - *Paper Cannot Wrap Up Embers*; **Feb 14** - *Broadcast from Yangon*, Burmese docs followed by a photographic Slide show by Virginie Noel; **Feb. 15** - *War/Dance and Without The King*, African docs; **Feb. 17** - *Kampuchea - Death and Rebirth*; **Feb. 18** - *Deacon of Death*, Khmer Rouge doc; **Feb. 19** - *Terrors Advocate*, a doc on Jacques Vergès, war criminal attorney; **Feb. 20** - *New Year Baby, Seasons of Migration*; **Feb. 21** - King Sihanouk's movies, *Shadow of Angkor, Rose of Bokor*; **Feb. 22** - *German Aid for Cambodia* (Nico Mesterharm); **Feb. 24** - *Vietnam American Holocaust*; **Feb. 25** - *The Gendered Lens*; **Feb. 26** - *Koyaanisqatsi, (Life out of balance)* soundtrack by Philip Glass; **Feb. 27& 28** - *Swim Against the Tide* followed by *With or Without Fidel*. 



**META HOUSE**  
PHNOM PENH

The State of Khmer Arts:  
**Visit Cambodia's first multi-media gallery!**

Tue - Sun, from 6PM  
 Rooftop Cinema starts 7PM  
 Chill-Out-Bar and BBQ

Street 264, #6 - Sangkat Chaktomuk, Khan Daun Penh, Phnom Penh  
 HOMEPAGE: www.meta-house.com EMAIL: mesterharm@gmx.net  
 FIXED: 023 - 224 140, MOBILE: 012: 607 465



**two fish studio**  
 house 2D, street 302 phnom penh

# leisure & wellness

## Nip and Tuck

With the emergence of an affluent Khmer middle class, more and more people are seeking a nose job or silicon implants. **Dr Reid Sheftall**, a plastic surgeon at the American Medical Center and Royal Rattanak Hospital sat down with **AsiaLIFE** to answer a few questions about the quest for perfection in the Kingdom and the pitfalls therein.

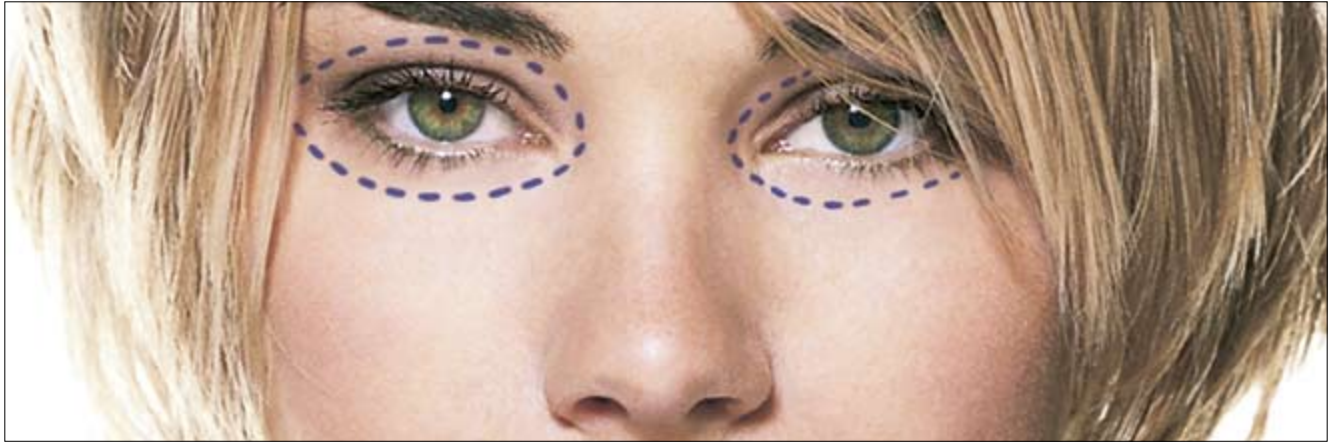

Make me beautiful

### ■ ASIALIFE: HAVE YOU SEEN AN INCREASE IN PLASTIC SURGERY RECENTLY?

**Dr. Reid Sheftall:** Yes. In the last year or so, the volume has increased two to three-fold.

### ■ WHAT ARE THE MOST COMMON COSMETIC PROCEDURES HERE IN PHNOM PENH?

In women, the most common procedure is breast augmentation. Then comes scar revision (mostly on the face), liposuction, tummy tuck, breast lift, nose augmentation, etc. We also do some Botox injecting. For men, almost all of the cases are liposuction mostly from the breast area or belly.

### ■ ARE MOST OF YOUR PATIENTS EXPATS?

Being American, most of my patients come from the States, naturally. Many are Khmer-Americans visiting family or vacationing here in Cambodia. After that in descending order I see patients from Vietnam, France, Thailand, Cambodia, other European countries, Australia and New Zealand, China and Singapore.

### ■ BEFORE OUR INTERVIEW YOU MENTIONED SOME DUPLICITOUS PRACTICES – SUCH AS FREE

### SILICON INJECTION – CLEARLY THIS IS SOMETHING YOU FEEL STRONGLY ABOUT?

Never allow anyone to inject free silicone into your body. This is against the law in the U.S. – for good reason. The free silicone can migrate to unwanted parts of your body and will surely form granulomas (hard round masses) that will be painful and disfigure your breasts and face. We regularly see patients who have had this done in Thailand or Cambodia and are coming in to have us remove the silicone. It is very hard to remove! And it involves an operation under general anesthesia. Then of course the breasts need to be reconstructed or augmented to look good again. It is best to avoid getting injected in the first place.

### ■ IS THERE ANY OTHER ADVICE YOU'D GIVE ANYONE THINKING OF HAVING SOME PLASTIC SURGERY?

Select a surgeon who has been formally trained to perform the procedures. There are many doctors and even non-doctors who come to places like Cambodia and Thailand, who do not know how to do the procedures. The results are frequently disastrous. Recently our practice has been dominated by women who have

come in to have us repair mistakes made locally.

### ■ CAN YOU GIVE ANY EXAMPLES?

One lady had lost her nipple and areola complex as the result of a botched breast reduction in Thailand. This happened in a famous hospital that many Cambodians used to go to. We were able to repair the wounds sufficiently – she also had flap necrosis from a bad tummy tuck by the same doctor – but she will need more reconstructive work in the future to be made cosmetically whole.

### ■ SO, HOW CAN WE TELL THE GOOD SURGEON FROM THE QUACK?

Ask to see examples of his or her work in the form of before-and-after pictures of previous patients. This is not an infallible way to choose a surgeon as we all tend to present only our best results – but it is better than nothing. Ask to see the doctor's credentials. Make sure he or she is the type of person who will see you through the entire process, complications included. Beware of any doctor who claims to have never had any complications. Anyone who has done enough procedures to be qualified to do this kind of surgery has had them.

### ■ BUT, SURELY PLASTIC SURGERY IS STILL EXPENSIVE?

The prices vary depending on which procedure you are having. We have kept our prices below the average fees in Thailand, which has been very helpful in getting our practice started. Starting with a lower price for the procedure itself and then adding the savings incurred in not having to buy plane tickets, airport tax, hotel rooms, taxi fares, etc. makes for a saving of around a thousand dollars for most procedures. The surgical fees are the same for Khmers and foreigners since we wish to provide this service at an easily affordable price for everyone.

*Dr. Reid Sheftall is the Chief of Surgery and Division Chief – Department of Plastic and Reconstructive Surgery at the Royal Angkor International Hospital in Siem Reap and Plastic Surgery Attending at the Royal Rattanak Hospital in Phnom Penh. He performs cosmetic and plastic surgery procedures at these hospitals and at the American Medical Centre, Hotel Cambodiana, Phnom Penh, which he founded in 2001. He can be reached at 023 991 863 or 012 591 041. ■*

# leisure & wellness

## amusement

### Kambol Cart Raceway

Tel: 012 232 332  
A few kilometers west of the airport is Phnom Penh's flashiest go-cart track. Boasting a 900m international standard size track complete with hairpin turns, a cart costs US\$7 for a 10-minute round. The track can also be rented by the hour, half-day or the entire day.

### Parkway Square

113 Mao Tse Tung Blvd,  
Tel: 023 982 928  
Ten-pin bowling alley with lanes costing between US\$6 and US\$9 per hour, depending upon the time of day. It also has a dodgem track, for those who haven't had enough of close shaves on the streets of Phnom Penh.

### Phnom Penh Water Park

50 Street 110,  
Tel: 023 881 008  
Traditional mix of slides and wave pools. Entrance is US\$2 weekdays (US\$3 at weekends). Open from 9.30am to 5.30pm.

### Phnom Tamao Wildlife Park

Phnom Tamao,  
44 kilometres out of the capital along Highway 2, lies Cambodia's best wildlife centre. All the animals are either rescued from traders or bred at the centre. Many of the animals are critically endangered. Open from 8am to 4pm.

### Sorya Centre

Corner Street 63 & 142  
The top floor of Phnom Penh's original shopping centre has a rink devoted to roller-skating and roller-blading. Hiring the skates or blades costs between US\$1 and US\$2.

## beauty products

### Angkor Soap

16 Street 374, Tel: 023 223 720  
www.angkorsoaps.com  
Specialising in handmade soaps and natural spa products.

### chemists

U-Care Pharmacy  
26-28 Sothearos Blvd., Tel: 023 222 499  
14 Sihanouk Blvd., Tel: 023 224 099  
High quality western-style chemist and pharmacy that sells the full range of beauty products, including international brands. Open 8am to 10pm.

### Pharmalink

11 Street 254, 14 Street 432  
20D Street 184, Tel: 023 215 727  
Modern, western-standard pharmacy on the way to the Russian Market. Staff speak English and have a range of western products on sale. Open from 7.30am to 8pm (Monday to Saturday).

## classes

### Cambodian Cooking Class

Frizz Restaurant, 67 Street 240  
Tel: 012 524 801  
The first and only Khmer cooking school for travellers and expats in Phnom Penh. Courses cost US\$20 for a full day, including transport to the market and a colourful 16-page recipe booklet.

### Capoeira

Tchou Tchou preschool, 13 Street 21  
Lessons in this rhythmic Brazilian cross between dance and martial arts, cost US\$2. Held every Monday and Wednesday from 6.30pm to 8pm. Contact Michel.

### Kids Create

Living Room, 9 Street 306  
Fun art classes for kids aged 4 to 12 on Wednesday from 3.30pm to 5pm. Call Leah Newman on 012 242 301.

### Little Maestro

Living Room, 9 Street 306  
Bring the Mozart out of your tot (0 to 6). Classes from 9am to 10am on Sundays. Call Melinda Burgess on 012 693 498.

### Photography Tours

126 Street 136,  
Tel: 092 526 706  
www.nathanhortonphotography.com  
Weekend photography tuition and guided tours to Kampong Chhnang and Udong, covering technical and creative considerations in the context of travel photography.

### Qigong

Living Room, 9 Street 306  
Qigong practice group meets every Monday and Wednesday at 5.30pm to 6.30pm. For more information contact, Phil 012 892 249.

### Scuba Nation Dive Center

18E0 Sothearos Blvd.,  
Tel: 012 715 785  
Learn to scuba dive in Phnom Penh. The academic part of the course takes place in the Plaza Hotel pool, while the real diving is over a weekend in Sihanoukville. Total cost for a course is US\$395.

## dental

### European Dental Clinic

160A Norodom Blvd.,  
Tel: 023 211 363  
French-run dental practice since 1994 which provides full dental hygiene services with modern equipment. Open 8am to 12pm and 2pm to 7pm (closed Sundays).

### SOS Dental Clinic

161 Street 51, Tel: 023 216 911  
International quality dental clinic, fully equipped with the latest equipment including dental cameras. US dentist

# Sam Moffett: A New Health Resolution



AS IT'S THE BEGINNING of a new year, be it Western or Chinese, getting back to optimum health is always an excellent goal, and for good reason! Regular exercise and good nutrition leads to a longer and better life. It's a proven fact.

Use it or lose it. Getting started, even here in Phnom Penh, isn't that tough.

Walk 10,000 steps a day. That may sound a lot, but it's only 75 minutes. Go for a daily walk of 15 minutes in one direction and return. That's 30 minutes. For the other 45 minutes just walk where you can. Most of it if you will complete in your daily routine.

Exercise your heart. It can be done in under 20 minutes per day if that's all you have, as long as you get it pumping and work up a sweat. Two to three times per week minimum.

Do some kind of weight exercises. Work out the

major muscle groups.

Two to three times a week – even for as little as 10 minutes is a great start.

Be sure to include squats. They are a good all-around exercise.

Drink lots of water or green tea. Avoid sugar. And by all means – do not drink coke.

Eat smaller portions, four to five times a day. Get in lots of green vegetables and fish or chicken. Try to limit your red meat intake. And never, ever skip breakfast.

Don't let the sniffles keep you from exercising. As long as it's just a head cold, with runny noses and sneezing, a lot of research now indicates it's actually beneficial to keep up a light exercise routine. I promise you, you'll feel better for it.

*Sam Moffett is manager of Clark Hatch Fitness Centre, Hotel InterContinental, 3/F Mao Tse Tung Blvd. ☐*



**ChamPei**  
Spa & Salon

Tired, Stressed, Want to relax...  
Come to enjoy our professional - Massage, Spa  
Steam, Sauna, Coffee

Tel: (855) 23 222 846, (855) 23 217 774, H/P: (855) 12 670 939  
E-mail: info@champeispa.com, www.champeispa.com

Address :  
1- House No. 38, St. 57, Boeung Heng Hang 1, Phnom Penh  
2- House No. 7, St. 334  
Working hours: 9:00 am to 11:00pm (Everyday)



# [ comfort zone ]

a complete sense of beauty

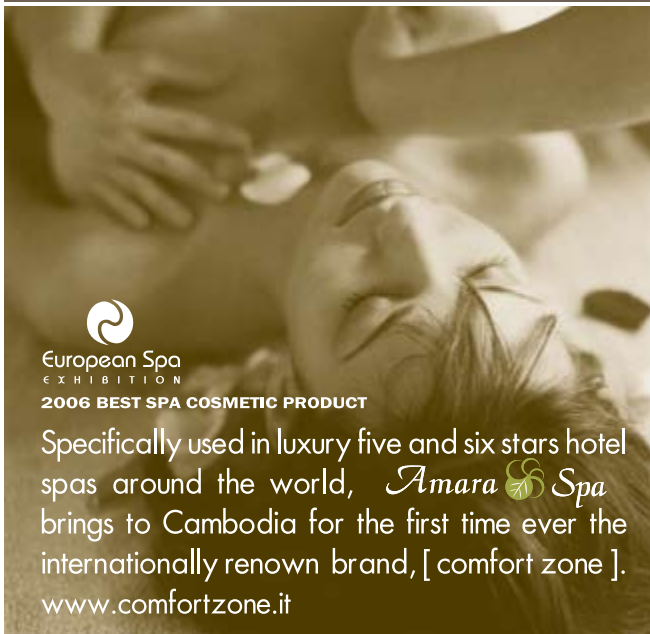

  
**European Spa**  
 EXHIBITION  
 2006 BEST SPA COSMETIC PRODUCT

Specifically used in luxury five and six stars hotel spas around the world, *Amara Spa* brings to Cambodia for the first time ever the internationally renowned brand, [ comfort zone ].  
[www.comfortzone.it](http://www.comfortzone.it)

[www.amaraspahotelcara.com](http://www.amaraspahotelcara.com) 023 998 730

## European Dental Clinic

160A, Norodom Bd (across ISPP South Campus)

Deborah Moore (UK) Dentist  
 Eric Le Guen (FR) Dentist  
 Channarith Penh (KH) Dentist  
 Angela Clifford (AU) Hygienist

Secretary : 023 211 363 / 012 893 174



- Scaling-polishing
- Crown & Bridge
- Whitening
- Orthodontic Treatment
- Root Canal Treatment
- Tooth Colored Filling
- Child Prevention
- Dental Implant

**Emergency**  
 092 804 471

012 986 024 / 012 854 408

explains the process of what is going on with your teeth and has multi-lingual staff.

### education

#### Khmer School for Expats and Travellers

35 Street 288, Tel: 012 867 117  
 Khmer-language lessons given on a one-to-one tuition basis only, costing US\$10 per hour, a typical course lasts for 30 hours.

#### Khmer School of Language

52G Street 454, Tel: 023 213 047  
 Khmer-language lessons given at the school for US\$4 per hour or for US\$5 in the privacy of your own home or office. All the teachers are experienced and trained at the school.

#### My First Khmer

PO Box 1498, Tel: 012 342 315  
 A network of university students offering language, translation, and interpreting services. Professional, affordable, and experienced. Call for a free lesson.

### gyms

#### Clark Hatch Fitness Centre

Intercontinental Hotel,  
 3/F Mao Tse Tung Boulevard,  
 Tel: 011 380 769

Well-equipped fitness centre run by a regional gym company that even has a rowing machine. Membership is US\$90 per month or US\$10 per day (US\$15 at weekends). Open 6am to 10pm (weekdays), 8am to 8pm (weekends)

#### Fitness One

Himawari Hotel,  
 313 Sisowath Quay, Tel: 023 214 555  
 Small, well-equipped gym with outdoor swimming pool. US\$6 per day for use of pool or US\$10 for pool, gym, steam room and jacuzzi. Prices rise to US\$8 and US\$12 at weekends.

#### Paddy's Gym

635 National Road 5,  
 just past the Japanese Bridge,  
 Tel: 012 214 940  
 Bearing the air of an American boxing gym, Paddy's offers an honest workout with recently imported equipment. Good range of free weights, boxing ring, boxing bags and aerobics. Entrance is US\$3 or US\$45 per month. Open from 6am to 8pm.

#### Raffles Amrita Spa

Raffles Le Royal Hotel,  
 Street 92, Tel: 023 981 888  
 Modern gym and pool in Phnom Penh's most elegant hotel. Use of gym, pool, sauna and jacuzzi costs US\$10 weekdays (US\$15 at weekends). Open from 6am to 10pm.

#### Physique Club

Hotel Cambodiana, 313 Sisowath Quay,  
 Tel: 012 810 432  
 Most modern of the five-star fitness centres with reasonable selection of equipment, although has a small changing area. Membership is currently US\$56

per month or US\$7 per day. Open from 6am to 10pm.

### VIP Club

Norodom Boulevard, Tel: 023 993 535  
 Large sports complex with gym, outdoor swimming pools, sauna, steam room and tennis courts. US\$6 per day for use of all facilities, monthly membership is US\$50 to US\$60. Open from 6am to 9pm.

### hairdressers

#### De Salon Hair Spa

31D Sihanouk Blvd.,  
 Tel: 023 223 938  
 Fancy new hair salon opened in late June by the same group that run Nata Spa.

#### Image Beauty

57Eo Street 240, Tel: 012 455 239  
 Khmer, English and Thai speaking stylists trained in hair, facial and nail treatment. L'oreal Professionnel products available. Free WiFi, tea and coffee provided.

#### New Jack Holt International

38 Street 57 (at Champei Spa),  
 Tel: 023 350 788  
 Contemporary hairdressers with a French-trained Khmer stylist. Offers the full range of hair treatments as well as nails and waxing.

### medical

#### American Medical Center

Ground Floor Cambodiana Hotel  
 313 Sisowath Quay,  
 Tel: 023 991 863  
[www.amc-cambodia.com](http://www.amc-cambodia.com)  
 Team of international and Khmer doctors that provide general practice services to clients, including the American Embassy. Can arrange emergency evacuation. 24-hour service.

#### International SOS Medical Clinic

161 Street 51, Tel: 023 216 911  
 Globally renowned provider of medical assistance and international health care. Team of expat and Khmer doctors offer general practice, specialist and emergency repatriation services. Has multilingual staff. Members have access to SOS clinics around the globe. Has on-site laboratory and dental facilities. 24-hour service.

#### Naga Clinic

11 Street 254, Tel: 023 211 300  
 French-Khmer run clinic with a team of international and Khmer doctors. Impressive range of modern facilities. Has a 24-hour pharmacy on site and can perform minor surgery. 24-hour service.

### optics

#### Eye Care

166 Norodom Blvd., Tel: 016 556 602  
 Modern opticians with ophthalmologists on hand to check prescriptions. Have an interesting range of glasses and lenses. Frames from under US\$100.

#### Grand Optics

71 & 75 Norodom Blvd, Tel: 023 213 585

## Pharm@link

- All your medical requirements
- Large choice of cosmetics
- First aid & personalized kits made upon your request
- Corporate partnership
- Free delivery service if needed (within PP area)
- Major credit cards accepted
- Multilingual staff

 CONTACT HEAD OFFICE: (+855) 23 215 727

PHARMALINK DAUN PENH #20B, street 184 - Phnom Penh MON-SAT > 7:30 AM - 8:00 PM  
 PHARMALINK NAGA CLINIC #11, street 254 - Phnom Penh 24/7  
 PHARMALINK BOEUNG TRABEK #14Eo, street 432 - Phnom Penh MON-SUN > 7:30 AM - 8:00 PM



# Beauty Spot: Om Traditional Massage

OM TRADITIONAL MASSAGE is a bit of a dark horse in the world of spas. Located on bustling street 278, only a small yellow sign above the stairway and a few employees lounging outside the entrance give away its location.

Once up the stairs you would not believe you were on the Golden Mile. The massage parlour is serene and the semi-private rooms are pleasantly low lit, and essential oils burn throughout treatments. Unfortunately some noise from the street does penetrate into the rooms, especially on in the evening, but not to a disturbing extent. The staff speak limited English, but short menus are available for you to indicate the type of massage desired, as well as its strength. Om employs both male and female masseurs, and given availability you can indicate a preference.

There are currently six types of massages available – foot (US\$8), Thai (US\$8US), back & shoulder (US\$10), head (US\$10), aromatherapeutic (US\$16) and Thai herbal (US\$16).

For the latter, you are taken to a treatment room, asked to remove your clothes and don a towel. Your feet are washed in floral water before laying down on the professional massage bed, which includes a hole for your face so that you are freed from the pain of a twisted neck during the massage. The oil smells faintly of lemon cough drops, quite pleasant really. The treatment encompasses your whole body, as well as your



face, though without the use of oil. It's not exactly deep tissue, but the scent of the oil and the masseuse's skilled strength make for a highly relaxing experience. Real herbal tea is served at the end of the session, and there is a bathroom available for making any necessary re-touches to your appearance after the treatment.

For a sore neck, Om's back & shoulder massage has few contenders in Phnom Penh. Borrowing some moves from Thai massage, this treatment focuses mainly on your upper body and is fantastic for releasing tension after hours in front of a computer screen. Ask for a male masseur if you want that extra bit of strength added to the kneading of your tired back.

## ■ THE VERDICT

The location is great, the staff are courteous and well-trained, and the prices are reasonable. During the back & shoulder massage, the masseur recognised particular tension points and focused on them, while the aromatherapy massage, though pleasant, was more of a 'run through the moves'.

Overall, Om is a fantastic little find that has attracted several customers to return over and over. It's not strictly a spa, as only massages are on offer, but they might as well capitalise on what they are good at and leave the rest to others.

*Om Traditional Massage, #3E1, street 278 (next to Equinox). Open daily 11am-11pm. Tel: 023 217 136. – NORA LINDSTROM*



**ក្រីពុំល្ងក**

*Khorpom Chhuk  
Massage - Spa & Salon*

*Unwind (with one of hour 1 or 2 hour massages,  
then pamper yourself at our full service Salon.  
Relax and let us take care you from head to toe.*



#29 Street 200, Sangkat New Market III, Khan Daun Penh, Phnom Penh, Cambodia  
(300 meters from Vattanak and Maruhan Banks) Tel: 023 990 394 / 012 222 898 / 017 377 719  
Derma Spa, #4C, St. 57, BKK 1 (next to Anise Hotel) Tel: 023 720 042

# Laura Watson: Whoever said romance is dead?

THE WARM GLOW OF A NEW romance may hide minor personality foibles but it should not hide the possibility that this person may be carrying a sexually transmitted disease such as Chlamydia.

*Chlamydia trachomatis* is a bacterial infection that can cause genital infection in both men and women. The most common sexually transmitted infection worldwide, it has an estimated 89 million new cases a year. Its prevalence varies with location. The incidence in U.K. surveys has been as high as 17 percent in some settings with an average of 5 to 10 percent in the general population. A survey in Cambodia in 2001 (Family Health International) showed that 22 percent of Cambodian sex workers tested, and 2 to 3 percent of the general population, had Chlamydia.

## ■ BECOMING INFECTED

You can get Chlamydia infection if you have unprotected sex with an infected person. Many men and women are unaware that they are infected, as it may not cause any symptoms. You can carry the infection for months or years without realising. An infected person with no symptoms may act as a reservoir in the community – especially if the person has many sexual partners – and may unwittingly spread Chlamydia to all such partners.

## ■ SYMPTOMS

Watch out for bleeding in between periods or after sexual intercourse, vaginal discharge, pelvic pain, or pain and burning while passing urine (especially for men). Men may also get discharge from the penis – most often white or grey rather than the green of gonorrhoea – although this isn't totally diagnostic.

If you have the infection, or think you may, it is important to get tested and treated – even if you have no symptoms. This is because the infection may spread and cause abdominal pain with fever (pelvic inflammatory disease), which can lead to scarring of the fallopian tubes and infertility. Sometimes infection in the



tubes may go undetected and cause 'silent' scarring. This is a common cause of infertility. If you are male you may pass this infection on to a partner and cause her to have fertility problems in the future. There is some evidence that Chlamydia infection in men can cause abnormalities in male sperm counts and infertility.

## ■ GETTING TESTED

Testing can be done in a variety of ways. The best test is one done on urine that looks directly for the presence of the bacterium. Unfortunately, this is not yet available in Cambodia. An alternative is to take a swab from the cervix and urethra and look for the organism living inside

these cells. This is pretty much the same procedure as having a Pap smear and can be done at the same time as routine screening. For a man, this test has to be done on discharge so it is difficult to do unless he has symptoms.

## ■ TREATMENT & PREVENTION

Treatment of asymptomatic infections is usually pretty straightforward and involves taking a short course of antibiotics. Your partner and any other recent partners would need to be tested and treated too. You should use condoms or abstain from sex until both you and your partner have completed the course of treatment.

You can prevent yourself from getting this infection by either both partners getting tested prior to commencing a sexual relationship or by careful, correct and consistent use of condoms. Remember to be prepared (carry a condom) and be in control (watch what you drink).

If you have been at risk of Chlamydia you may also have a risk of other sexually transmitted infections and should seek advice and testing from your doctor.

*Acknowledgements:*  
[www.patient.co.uk](http://www.patient.co.uk) and  
[www.chlamydiae.com](http://www.chlamydiae.com)

*Laura Watson is a general practitioner at the International SOS Medical Clinic in Phnom Penh. For more information please email: [sue.kemp@internationalsos.com](mailto:sue.kemp@internationalsos.com).*

ERIQ AMTALLA  
phnom penh

## Unisex Hairdressing

located at Gasolina,  
first floor St. 57 No. 56-58

open. tues-thurs 10 a.m. - 6 p.m.,  
fri-sat 10 a.m. - 8 p.m.

tel. 017.839.546  
email. [ekichana@yahoo.com](mailto:ekichana@yahoo.com)

appointments preferred

Facial treatment  
Specialist  
Rejuvenates your skin  
Anti-Aging treatment

Hair Stylist  
Beautician

L'OREAL  
PARIS

For reservation  
Call: 012 455 239

We speak  
Khmer-English-Thai  
Facial Treatment  
Hair Treatment  
Nail Treatment  
Massage



FREE Wi-Fi Internet  
Tea selection - Coffee - Espresso

57AE0, Street 240  
Phnom Penh

# National Rugby League - 6 Day

Senior, U17, U15 and U13 Programme –2009 January 18th, Old Stadium

No.	TIME	AGE GROUP		
1	12h15	U17	Sisowath	Tiger
2	12h45	U15	Sisowath	Lycee Français Aspeca
3	13h15	U13	Sisowath	Lycee Descarte
4	13h15	U13	Moan	Aspeca
5	13h35	U15	Lycee Français Aspeca	Cats
6	14h05	U13	Aspeca	Sisowath
7	14h05	U13	Moan	Lycee Descarte
8	14h25	U15	Cats	Sisowath
9	14h55	Senior	Garuda	Sisowath Knights

End of the games: 5:00pm

## Open Palm Studio

12 Street 101, Tel: 012 633 278  
The first official Spinning facility in Phnom Penh. Tuesdays and Thursdays at 8.15am. Call to book in advance.

## VIP Club

Norodom Boulevard, Tel: 023 993 535  
Large sports complex with gym, outdoor swimming pools and tennis courts. Open from 6am to 9pm.

## spas

### Amara Spa

Cnr. Sisowath Quay & Street 110,  
Tel: 023 998 730, 012 873 999  
Fax: 023 998 731  
www.amaraspa.hotelcara.com  
A unique & comprehensive Day Spa providing a wide selection of facials, body massages and treatments; arranged into four storey sophisticated modern facility. Open from 11am to 11pm

### Amret Spa

3 Street 57,  
Tel: 023 997 994  
Stylish spa with treatments in individual rooms. Also has rooms for couples with Jacuzzi. Open from 9am to 9pm.

### Aziadee

16AB Street 282,  
Tel: 023 996 921  
Very relaxing, air-conditioned massage parlour with individual rooms.

### Bliss

29 Street 240, Tel: 023 215 754  
Health spa at the back and upstairs in this beautiful French colonial building. Have a massage, facial, body scrub or simply wallow in the beautiful flower bath. Open 9am to 9pm, closed Monday.

### Champey Spa & Salon

38 Street 57, Tel: 012 670 939  
www.champeyspa.com  
Beautiful spa in the heart of Boeung Keng Kang 1 district. Has a full range of massages and body treatments. Open from 9am to 11pm.

### Dermal Spa

4C Street 57, Tel: 012 222 898  
Spa offering beauty salon, foot massage and body massage services. Specialises in dermalogica skin and beauty products.

### In-Style

63 Street 242, Tel: 023 214 621  
Set in beautiful villas, the lovely gardens and revitalising café that greet your entrance indicate that this is more than just a spa. Full range of massages and beauty treatments with an emphasis on the Balinese.

### Kropom Chhuk

29 Street 200, Tel: +855 (0) 23 990 394  
Khmer owned with Thai trained masseurs. Same ownership as Dermal spa. In a large old house centrally located. Salon Open from 9am to 9pm

### Master Kang Health Care Centre

456 Monivong Blvd.,  
Tel: 023 721 765  
Large health centre next to Man Han Lou Restaurant. Offers foot massage in either public or private rooms downstairs, with both Chinese and oil massage upstairs. Downstairs also has a grand piano which is played in the evenings.

### Miss Care & Spa

4B Street 278, Tel: 023 221 130  
Small beauty parlour and spa set on the Golden Street, with well-priced massages range and beauty treatments.

### Punarnava

Ayurveda Centre Spa,  
Hotel Cambodiana,  
313 Sisowath Quay, Tel: 012 810 432  
Traditional Indian-style Ayurveda massage and healing that can provide relief to a range of physical ailments. All staff are professionally trained.

### Sawasdee Massage

6B Street 57, Tel: 023 996 670  
Oil, Thai-style and foot massage are available from trained masseuses in this excellent parlour, which also does beauty treatments. For a few dollars more than the dorm-style mattress massages, you can have the privacy of your own room.

### Seeing Hands Massage

6 Street 95, 209, 246, 253 Street 53  
Tel: 016 856 188  
String of massage parlours where the service is provided by the blind at a very reasonable price.

## sports general

### Cambodian Federation of Rugby

cambodianfederationofrugby.com  
Proper 15-a-side rugby league with four senior teams as well as kid's touch and women's rugby teams. Contact Larry at khmer\_rugby@yahoo.co.uk for more details.

### Cambodia Golf & Country Club

Route 4, Tel: 023 363 666  
International standard, 18-hole golf course.

### Cricket

Infrequent fun games played at a school off Street 360, near Street 63, on Sunday mornings. No equipment required and little prior knowledge of the rules is also ok. Contact Majid at Saffron Wine Bar on 012 247 832.

### Football: The Bayon Wanderers

www.bayonwanderers.com  
Mixed Khmer and western team. Training sessions at the International School of Phnom Penh on Tuesdays from 5pm and Thursdays from 6.30pm. Contact Billy Barnaart on 012 803 040.

### Hash House Harriers

The Hash meets at the railway station every Sunday at 2:15pm. An ideal way to see the countryside either walking or running, and then to make a public (school) exhibition of yourself. Contact 012 832 509 for details.

### Nataraj Yoga Center

No. 52, street 302,  
(bet. 63 and Monivong),  
Tel 855 12 250 817,  
www.yogacambodia.com  
Classes daily: Yoga, Pilates, check website for schedule and prices.

### Pangolins Rugby Club

Expat rugby team that plays others in the region. Also has female rugby team called the Apsaras. Mixed touch rugby at Northbridge School on Saturdays at 3.30pm. Contact Greg Eggins on 012 810 900.

### Royal Cambodia

Phnom Penh Golf Club, National Road 4  
The other international standard golf course.

## tennis

### The Club at Northbridge

1km off National Road 4, Tel: 023 886 012  
Excellent tennis court. Book in advance.

### VIP Sport Club

Norodom Boulevard, Tel: 023 993 535  
Courts are available for hire by the hour or for members. 📞

# next generation

## Poolside

Phnom Penh is situated on the confluence of three rivers, but that doesn't mean people know how to swim. **Angela Savage** interviews **Andrew Schultz** about his efforts to teach water safety skills, and looks at child-friendly pools in the capital.



We can swim at CAMSWIM

■ **SWIMMING CLASSES FOR KIDS** 'High five!' says Andrew Schultz as the three-year-old successfully steers her kickboard across the pool.

With a friendly style and the energy to match a toddler, Andrew is a natural teacher. His praise helps reinforce the skills and confidence the child is developing as a pupil in his 'tadpole' swimming class.

Andrew arrived in Phnom Penh in October 2007. With a background in health promotion, and qualifications as a swim instructor (Austswim) and exercise physiologist, he looked around for a way to harness his interests to what he describes as an 'exciting environment for business, where you can try new things out.'

'I was surprised by the interest people had in learning to swim here,' he says, 'and also by the lack of ability.'

Data from Thailand and Vietnam showed high rates of death by drowning, and there was evidence to suggest the situation was similar in Cambodia. Andrew knew that teaching people to swim helps prevent drowning, and his straw poll suggested there was a local market for swimming lessons.

Thus CAMSWIM was born, with swimming lessons for children and adults. From its base at the pool at the Phnom Penh Centre on Sothearos Boulevard, the business has grown steadily to offer 16 classes per week.

Kids classes are offered in 14-week terms, three per year, at a cost of US\$4 for expats and US\$2.50 for Khmers per class. The term last month, but participants can start at any time and pay for the remaining number of classes in the term. The classes attract roughly equal numbers of locals and expats.

'The parents of toddlers enjoy seeing quick improvement and progress in their children's skills,' Andrew says, 'such as being able to put their face under and move independently in the water.'

And as for the children, 'Kids love the songs we sing. For them, it's learning through play.'

Children learn to swim fastest around the age of four to five. But they are at highest risk of drowning between the ages of one to four. Andrew teaches water safety skills for babies as young as six months.

'The main thing is that if they're not in the pool themselves, parents should only ever be an arm's length away from their children and should watch them intently when they are in the water.'

### ■ SWIMMING CLASSES FOR ADULTS, TOO

Expatriate parents should also be aware that Khmer nanny's

who care for their children might not be able to swim, and might consider investing in swimming classes for carers. With adult classes costing US\$3 for Cambodians and US\$5 for expatriates and following the same 14-week terms, it's a relatively small investment for a life-long, potentially life-saving skill.

Andrew's current challenge is to train up local staff to become fully-fledged swim instructors, to meet the shortage of swimming teachers in Cambodia.

When it comes to kid-friendly pools in Phnom Penh, Andrew recommends choosing a place undercover or with plenty of shade. In most cases, it costs less to attend one of his half-hour classes than it does to swim in one of the pools listed below.

# next generation guide



A network protecting children from all forms of abuse. [www.childsafe-cambodia.org](http://www.childsafe-cambodia.org).

## KID-FRIENDLY POOLS IN PHNOM PENH

The Villa Langka is our family's favourite. The pool isn't huge but it's clean, the lush garden always offers shady places, and the pool usage fee can be off-set against the cost of food and drinks. Cost weekdays US\$5/adult, US\$3/child; weekends US\$8/adult, US\$5/child.

The Himarawi Hotel has a large outdoor pool, separate kids' pool and Jacuzzi. Cost of pool use weekdays US\$7/adult, US\$4/child aged 10-15 years and US\$3/child aged 5-9 years; weekends US\$8/adult, US\$5/child aged 10-15 years and US\$4/child aged 5-9 years. Children under 5 swim free.

The Billabong is a family-friendly hotel with a shady poolside area and open-air restaurant. Pool use costs US\$5 for adults, US\$3 for children.

Kabiki is a family-friendly hotel run by the same people who run the not-so-family friendly Pavilion. The Kabiki has a separate kids' pool and covered day-beds in a spacious garden. Pool use for non-guests is US\$5 for adults, US\$3 for kids.

The Parkway Health Club on Mao Tse Tung Boulevard near Spark Red has a large indoor pool with a semi-circular kids' section at one end. Entrance fee of US\$8 is on the steep side but provides access to the gym and sauna.

Children can use the pool for free at L'Imprevu Resort, Highway 1, 7km past the Monivong Bridge. Cost for adults is US\$4 at weekends, US\$2 on weekdays. The separate kids pool is in a shady area.

## CAMSWIM

**Andrew Schulz**  
Tel: 017 986 297 [camswim@mail.com](mailto:camswim@mail.com)

## Villa Langka

14 Street 282, Tel: 023 726 771  
[www.villalangka.com](http://www.villalangka.com)

## Billabong Hotel

5 Street 158, Tel: 023 223 703

## Kabiki Boutique Hotel

22 Street 264, Tel: 023 222 290  
[www.thekabiki.com](http://www.thekabiki.com)

## Parkway Health Club (Parkway Square)

113 Mao Tse Tung Boulevard.  
Open 6am-10pm.

## L'Imprevu Resort

Highway 1, 7km past the Monivong Bridge. Ph 012 655 440 [www.hotelimprevu.com](http://www.hotelimprevu.com)

## cafés & restaurants

### Annam

1C Street 282,  
Tel: 023 726 661  
In addition to serving excellent Indian food on a beautiful terracotta terrace, this Indian restaurant also has a playroom with a trained member of staff to ensure your little one gets up to no harm while you eat your chicken korma.

### Café Fresco II

Cnr. streets 51 & 306,  
Tel: 023 224 891  
Let your children play with puzzles and Lego on beanbags or watch films like the Lion King looked after by a trained member of staff as you enjoy your cappuccino.

### Café Living Room

9 Street 306,  
Tel: 023 726 139  
The playroom is stocked with books, games, wooden dollhouse and even a rattan crib, while the kid's menu has bite-sized portions. In addition to art classes there are plans to hold story-telling lessons.

### Gasolina

56/58 Street 57,  
Tel: 012 373 009  
Has weekly Saturday and Sunday brunches from 10am to 3pm for parents and their children. Also has the biggest garden in town for kids to wander around in.

### Intercontinental Hotel

296 Mao Tse Tung Blvd.,  
Tel: 023 424 888  
The five-star hotel has a special activities corner for kids to play while parents enjoy Sunday Brunch from 11.30am to 3pm, including free-flowing Moët & Chandon champagne. A nanny is on-hand, and under-6s get to eat for free.

### Java Café

56 Sihanouk Blvd.,  
Tel: 023 987 420  
Kid's menu includes chicken nuggets and pizza bagels and there are colouring pages and crayons to keep the kids amused. High-chair is available on request and baby-changing facilities are in the toilet.

### Java Tea Room

Inside Monument Books, 111 Norodom Blvd., Tel: 092 451 462  
Cheerful children's reading room has picture books, puzzles, art supplies and occasional story-telling sessions. Open from 8am to 8pm.

### Le Jardin

16 Street 360,  
Tel: 011 723 399  
This garden retreat has a great kids' area with playhouse and sandbox. Specialises in birthday parties, with cake, decorations, toys and drawing materials provided for US\$7 per child.

### Romdeng

74 Street 174, Tel: 092 219 565  
Large garden and swimming pool provides kids with plenty of opportunity to work off all that energy. Half of the Khmer dishes can be ordered in half-portions. If your kids like creepy-crawlies, they might just take on the crispy tarantulas.

### Kids Create

Café Living Room, 9 Street 306,  
Tel: 023 726 139  
Art classes with Leah Newman each Wednesday at Café Living Room, from 2.30pm to 3.25pm for 2 to 3-year-olds and from 3.30pm to 4.15pm for 4 to 6-year-olds.

### Khmer

**Gecko & Garden Pre-school,**  
1 Street 282, Tel: 092 575 431  
Khmer classes for children from 2.5 to 6-year-olds from 3pm to 5pm on Wednesdays and Fridays, costs US\$96.

### Yoga

**Gecko & Garden Pre-school,**  
1 Street 282, Tel: 092 575 431  
Yoga lessons with Georgina Treasure for 3 to 5-year-olds from 3pm to 4pm on Tuesdays. Drop-ins welcome (US\$6)

## entertainment

### Kabiki Hotel

22 Street 264, Tel: 023 222 290  
The first hotel designed specifically for families, Kabiki has a salt-water swimming pool and large garden for kids to ride around on bicycles in. Menu has child-friendly dishes like chicken nuggets. Swimming is free so long as you spend US\$5 in the restaurant.

### Kambol Cart Raceway

Tel: 012 232 332  
A few kilometers west of the airport is Phnom Penh's flashiest go-cart track. Boasting a 900m international standard size track complete with hairpin turns, a cart costs US\$7 for a 10-minute round. The track can also be rented by the hour, half-day or the entire day.

### Parkway Square

113 Mao Tse Tung Blvd, Tel: 023 982 928  
Ten-pin bowling alley with lanes costing between US\$6 and US\$9 per hour, depending upon the time of day. It also has a dodgeball track, for those who haven't had enough of close shaves on the streets of Phnom Penh.

### Phnom Penh Water Park

50 Street 110, Tel: 023 881 008  
Traditional mix of slides and wave pools. Entrance is US\$2 weekdays (US\$3 at weekends). Open from 9.30am to 5.30pm.

### Phnom Tamao Wildlife Park

Phnom Tamao,  
44 kilometres out of the capital along Highway 2, lies Cambodia's best wildlife centre. All the animals are either rescued from traders or bred at the centre. Many of the animals are critically endangered. Open from 8am to 4pm.

### Sorya Centre

Corner Street 63 & 142  
The top floor of Phnom Penh's original shopping centre has a rink devoted to roller-skating and roller-blading. Hiring the skates or blades costs between US\$1 and US\$2.

### Villa Langka

14 Street 282  
This family-friendly boutique hotel has a large pool where kids are allowed to splash about. The menu has a short children's section and use of the pool is free so long as adults spend US\$8 and children US\$5 at the restaurant.

## pre-schools

### Gecko & Garden Pre-school

1 Street 282, Tel: 092 575 431  
This not-for-profit pre-school, established ten years ago, emphasises learning through creative play in a supportive environment. The Kids Club, for 18 months to 5-year-olds, is from 3.15pm to 4.45pm on Mondays, Wednesday and Thursday and costs US\$80 per child (Sep. to Dec.). Also has yoga and Khmer classes.

### Giving Tree Preschool

17 Street 71, Tel: 017 997 112,  
[www.thegivingtreeschool](http://www.thegivingtreeschool)

Play-based programme in both English and French includes storytelling, music, theatre, role-play, dance and gym with large outdoor play area, playground with sandbox, and swimming pool. Takes kids from 18 months to 5 years, either half-day (8am to 12pm) or full-day (8am to 4.30pm).

### Kindercare

60 Street 322, Tel: 023 214 890  
Kindergarten set in the heart of Boeung Keng Kang district I.

### Tchou Tchou

13 Street 21, Tel: 023 362 899,  
[www.tchou-tchou.com](http://www.tchou-tchou.com)  
Kindergarten and pre-school for 18 months to 5-year-olds, open from Monday to Friday from 7.30am to 12pm. French is the main language, although English and Khmer is also practised.

## international schools

### ICan International School

85 Sothearos Blvd, Tel: 023 222 418  
[www.ican.edu.kh](http://www.ican.edu.kh)  
International school teaching the English national curriculum to over 230 pupils. Has spacious and modern facilities.

### International School of Phnom Penh

146 Norodom Blvd, Tel: 023 213 103  
[www.ispp.edu.kh](http://www.ispp.edu.kh)  
Not-for-profit international school founded in 1989, ISPP has 395 students from pre-school to Grade 12. It is the largest international school in Cambodia, and the only authorized IBO school in the country.

### Lycée Français René Descartes

Street 96, Tel: 023 722 044  
[www.descartes-cambodge.com](http://www.descartes-cambodge.com)  
French school offering primary and secondary level education, extra-curricular activities include basketball, football and rugby.

### Northbridge School

1km off National Road 4 on the way to the airport, Tel: 023 886 000  
[www.niscambodia.com](http://www.niscambodia.com)  
Quality international school with curriculum for students from pre-school to high school as well as good sports facilities.

### Zaman International School

2843 Street 3, Tel: 023 214 040  
[www.zamanisc.org](http://www.zamanisc.org)  
International school that teaches a full curriculum to children from four to 18. Facilities include basketball and volleyball courts, a football field and a science lab.

## shops

### Jolly Baby & Kids

108-110 Kampuchea Krom, Tel: 012 995 795  
Wholesale and retailer store that sells clothing and toys for children.

### Farlin Showrooms

129 Monivong Blvd,  
175A Mao Tse Tung Blvd., Tel: 023 228 222 / 012 875 222  
Sells a variety of products for babies and mothers imported from Taiwan, Singapore and Hong Kong.

### Kid's World

112 Sothearos Blvd., Tel: 012 661 168  
Bright and cheery children's store selling an extensive range of real Lego, from small pieces up to elaborate box sets such as build-your-own Ferraris. The store also features a small play table. A range of baby products under the 'Nuk' label are also available.

### Monument Toys

111 Norodom Blvd., Tel: 023 217 617  
To the rear of Monument Books is a well-stocked toy section. It features an excellent range of well-known board games and toys including Barbie dolls, Transformers, Magic 8 balls and more. It has to be the best place in the city for brand name toys and games.

### Willi Shop

769 Monivong Blvd., Tel: 023 211 652  
All products are imported from France, including bébé brand baby products, the range includes prams, baby care, coats and toys. Open from 8am to 8pm.

# shopping & fashion

## Handbag Heaven

No woman's outfit should ever be without the perfect handbag. This month **AsiaLIFE** has scoured the city for the best options from multiple locations and various price brackets.

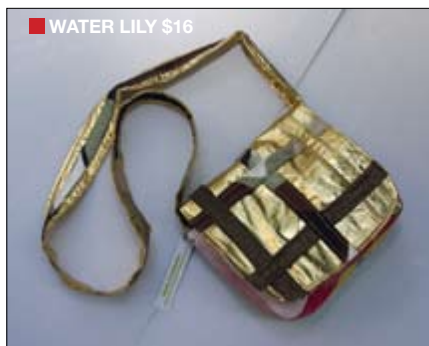



■ AMBRE \$180



■ COULEURS D'ASIE \$16



■ RAJANA \$13.75

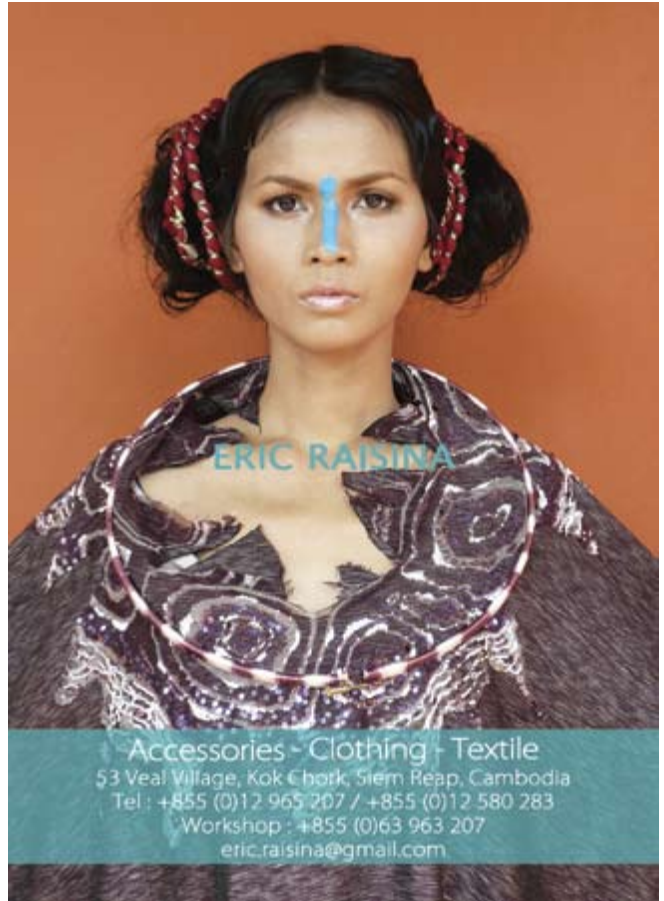

ERIC RAISINA

Accessories - Clothing - Textile  
53 Veal Village, Kok Chork, Siem Reap, Cambodia  
Tel : +855 (0)12 965 207 / +855 (0)12 580 283  
Workshop : +855 (0)63 963 207  
eric.raisina@gmail.com

beyond  
interiors



SHOWROOM No. 14, ST. 306. BKK1  
EMAIL: INFO@BEYONDINTERIORS.BIZ  
WEBSITE: WWW.BEYONDINTERIORS.BIZ  
HP: +855 12 930 332 PH: +855 23 987 840

Create Your Lifestyle  
live your style

**Bloom**  
ATELIER

*Bazaar*  
art de vivre

28, Sihanouk Blvd, Phnom Penh  
Tel: 012 776 492  
maj\_ksa@yahoo.com

# Threads

Women's and Men's Clothing  
Cottons and Silks

Now Selling Fair Trade  
Silk Lingerie By Shenga

56 E1z Boulevard Sihanouk  
Tonle Bassac, Phnom Penh  
(Behind Java Café)

## Angkor Soaps®

Handmade Natural Soaps & Spa Products

No.16C, Street 374, Chamkarmon, Phnom Penh, Kingdom of Cambodia  
E-Mail: admin@angkorsoaps.com WEB SITE: www.angkorsoaps.com  
Tel.& Fax: (855) 23 223 720

### Handmade Soap for Body and Soul

**Also available at: Kravan House, Living Room, Sab Bay**

# shopping guide

**ChildSafe®**  
A network protecting children from all forms of abuse. [www.childsafe-cambodia.org](http://www.childsafe-cambodia.org)

## art

**Happy Painting Gallery**  
FCC; Domestic Airport  
[www.happypainting.net](http://www.happypainting.net)  
Open since 1995, these popular aircon art shops sell the extremely colourful and positive works of iconic artist Stef. Accepts all major credit cards. Open from 8am to 10pm.

## books & cds

**Carnets d'Asie**  
French Cultural Centre (FCC)  
218 Street 184, Tel: 012 799 959  
French-language bookshop that has sections on Cambodia and Asia as well as general fiction. Good range of French magazines and newspapers. Open from 8am to 8pm (closed Sundays and holidays).

**D's Books**  
12E Street 178 & 79 Street 240  
Tel: 092 675 629  
Over 20,000 copies. Most are second-hand, but some are originals. Heavy emphasis on best sellers, National Geographic past-issues and travel books. Open 9am to 9pm.

**Monument Books**  
111 Norodom Blvd., Tel: 023 217 617  
Extensive range of new English-language books in town including recent releases and sections on Asia, Cambodia, travel, cuisine, design and management. Good children's section as well as a wide choice of magazines and newspapers. Open from 7:30am to 7pm (7.30am to 5.30pm Monday).

**Open Book**  
41Eo Street 240  
A welcoming reading room open to anyone to drop in, with a good range of children's books in English, French and Khmer. Apart from the library books, there's a range of illustrated children's books in multiple languages for sale. You may need to ask a staff member for assistance, as the books for sale are locked in a cupboard.

## crafts & furniture

**Artisans D'Angkor**  
Craft Centre Tel: 063 963 330  
Silk Farm Tel: 063 380 375  
Specialising in stone and wood carving, lacquering and silk paintings. All items are hand made by the students at the training centre. Both the training centre and the silk farm are open to the public for tours and workshops.

**Bazar Art de Vivre**  
28 Sihanouk Boulevard, Tel: 012 776 492  
Elegant furniture and home fittings shop that specialises in antique furniture, furnishings by Bloom Atelier and Cambodian silks. French-Vietnamese owner Mai also

specialises in calligraphy and design. Open from 9am to 6pm (closed Sunday).

**Beyond Interiors**  
14e Street 306, Tel: 023 987 840  
This interior design showroom, managed by Australian designer Bronwyn Blue, can provide the ultimate design solution to your interior dilemma. All products from Thailand, Vietnam, Indonesia and Cambodia are made with travel in mind and have been treated to withstand any climate. Open 7 days, 9am to 7pm

**Chez l'Artisan**  
42D Street 178, Tel: 012 869 634  
Quaint shop with high-quality wooden furniture and lampshades that also produces made-to-measure goods on request. Just make sure you don't trip over the dog on the way in. Open from 10am to 6pm.

**Hidden Treasures**  
9 Street 148, Tel: 012 717 212  
Antique shop tucked just around the corner from Riverside Bar. Has a surprisingly large selection of antiques.

**I Ching Decor**  
85 Sotheaors Blvd., Tel: 023 220 873  
[www.ichingdecor.com](http://www.ichingdecor.com)  
Boutique interior design shop offering advice on architectural work and interior design, as well as providing custom-made furniture, home accessories, kitchenware, lighting and bedroom suites.

**Le Rit's**  
14 Street 310, Tel: 023 213 160  
Restaurant and boutique handicraft shop run by the NGO NYEMO, set in a beautiful garden. Open from 7am to 5pm, closed Sundays.

**Pavillon d'Asie**  
24 - 26 Sihanouk Blvd., Tel: 012 497 217  
Antique lovers dream, with a large array of well-restored furniture and decorative objects. Wooden cabinets jostle for space with Buddha statues and old wooden boxes. Upstairs are pieces from the French colonial era. Open 9am to 6pm. Closed Sundays.

## computers

**S.I. Computer Technology**  
43-45 Street 43-45, Tel: 023 216 699  
93 Sihanouk Blvd., Tel: 023 218 880  
Top quality computer shop room for company that deals in latest computer equipment. Retail a range of Fujitsu LifeBooks, including the U1010, T2010, T4220, S7111 and the award-winning S6410.

## fashion

**Ambre**  
37 Street 178, Tel: 023 217 935,

# Jasmine Boutique

Kingdom of Cambodia [www.jasmineboutique.net](http://www.jasmineboutique.net)

#73, Street 240, Phnom Penh, t: +855 (0)23 223 103  
FCC Angkor, Pokambor Ave, Siem Reap, t: +855 (0)63 760 610  
e: [jasmineboutique@online.com.kh](mailto:jasmineboutique@online.com.kh)



012 688 608

High-end fashion designs created by Cambodian designer Romyda Keth that are popular all over the world. Beautiful colonial building with colour-themed rooms makes the perfect setting for the city's most glamorous design shop. Open 10am to 6pm (closed Sunday).

**Beautiful Shoes**

138 Street 143, Tel: 012 848 438  
Located near Tuol Sleng Museum, this family-run business measures your feet and designs the shoe exactly as you wish. The shop also caters for men. Open from 7am to 6.30pm.

**Bliss**

29 Street 240, Tel: 023 215 754  
A beautiful colonial building houses this exquisite shop with funky patterned cushions, quilts and an excellent clothing line. The health spa at the back of the shop also sells Spana beauty products. Open from 9am to 9pm (closed Monday).

**Eric Raisina**

53 Veal Village, Siem Reap  
Tel: 012 965 207 / 063 963 207  
Accessories, home decorations, textiles and clothing created by Malagasy-born and French-trained designer. His amazingly vibrant designs have collected quite a following throughout the fashion world.

**Jasmine Boutique**

73 Street 240, Tel: 023 223 103  
www.jasmineboutique.net  
Established in 2001 by Kellianna Karatau and Cassandra McMillan, this boutique creates its own collection of designs twice a year using hand-woven Cambodian silk. Open 8am to 6pm.

**Kambuja**

165 Street 110, Tel: 012 613 586  
Stylish fashion outlet with clothing designed to fuse west with east.

**Keo**

92 Street 222, Tel: 012 941 643  
Haute couture fashion house run by Sylvain Lim, the grand master of Cambodian fashion. Has some pret a porter too.

**L'Armoire**

126 Street 19, Tel: 012 830 551  
Designer Alexandra Barter describes her collection as "Cambodian tropical". With women's fashion, accessories and homeware, Alexandra's range is stylish and wearable, ideal for expats in Cambodia. Open from 10.30am to 5.30pm, closed Mondays.

**MDSF**

151B Street 199, Tel: 017 467 986  
www.wpp-we.org/mdsf  
Small garment factory produces simple clothes and bags. Proceeds go to support women living with HIV and their children in Cambodia.

**Sapors**

11 Street 59, Tel: 012 900 470  
Modelling agency, training school for house-keeping, as well as a beauty training school.

**Smateria**

8Eo Street 57, Tel: 012 647 061  
Boutique specialising in accessories

made from recycled materials including a range of bags and wallets made from old fruit juice cartons, plastic bags and mosquito nets.

**Spicy Green Mango**

4a Street 278 Tel: 012-915-968  
29 Street 178 Tel: 023-215-017  
Now open in two locations, designer Anya Weis offers a very different style of clothing to any other shop in Phnom Penh with imaginative, colourful skirts, trousers, t-shirts, belts and shoes.

**SONG**

75 Street 240, Tel: 092 985 986  
www.songresort.com  
Franchise of the Vietnamese-based SONG label owned by Keo Sophea who used to manage Kambuja. Features casual wear for both men and women designed by Valerie Gregori McKenzie.

**Threads**

56 E1 Sihanouk Boulevard  
(behind Java Café), Tel: 012 768 248  
Unisex boutique tucked away behind Java Café that sells the designs of owner Linda.

**Water Lily**

37 Street 240, Tel: 012 812 469  
Eclectic shop run by Christine Gauthier selling her distinctive range of colourful unique necklaces (US\$10 to US\$500), beads, earrings, flamboyant hats (from US\$26) and bags (US\$35). Open 8am to 5.30pm (closed Sunday).

**Zoco**

22B Street 278, Tel: 017 755 964  
Fashion boutique run by the Spanish-born Nurie, sells dresses, skirts, bags and accessories, with dresses from US\$10. Has another store on the way to Serendipity Beach in Sihanoukville.

**food**

**Alpine Trading**

13 Street 90, Tel: 012 961 084  
This quality European beer importer supplies restaurants, cafes and bars.

**AusKhmer**

125 Street 105, (between Streets 348 & 330), Tel: 023 214 478  
Excellent source of Australian beef and lamb and also has groceries, wines, beers by the case or six pack, plus a great range of imported cheeses. This major supplier of cafes and restaurants is also open to individuals who can check out the warehouse style store and coolrooms.

**Bong Karem**

Shop at WarpZone, Pencil Supercenter (opposite Cambodiana Hotel), Tel: 092 235 336  
Italian gelato delivered to your door! Also available at Kabuki, Meta House, La Veranda, Living Room, Cafe Yeji. Delivery available from 12pm to 5pm.

**Butcher & Co.**

219 Street 19, Tel: 023 223 527  
Quality French butchers in the same building as Open Wine. The meats here are some of the finest cuts in the city.

**Sobhana Boutique**  
No. 23, St. 144/49, Sangkat Phsar Thmey III, Khan Daun Penh, Phnom Penh, Cambodia.  
Phone: (+855 23) 215 455  
Email: sobhana@sobhana.org  
www.sobhana.org

Siem Reap Angkor International Airport  
Tel: (855) 63 964 727

22B ST 278 PHNOM PENH  
TEL: 017 755964

**ZOCO CLOTHES**

CLOTHES THAT YOU WANT TO WEAR

**Kambuja**  
Contemporary Clothing Designed for You...

*Live Style*

165 Ang Duong Boulevard, Phnom Penh, Cambodia Tel: 012 413586

**Safe and Healthy Food**

**Peri-Urban Agriculture Centre (PUAC)**  
Chemical Residue Free Vegetables • Produced by Khmer Farmers • Door Delivery Service

www.puac.info  
012 63 83 71 / 011 58 88 81  
Shop : # 213B, St. 63, Beng Keng Kong I, Phnom Penh

www.couleursd'asie.net  
 #33, Street 240, Phnom Penh  
 Tel./Fax 855 23 221 075, info@couleursd'asie.net



**COULEURS  
 D'ASIE**

GIFTS . HOME DECO  
 SILK COLLECTIONS  
 SPECIAL ORDERS



**Accessorize that new handbag at Water Lily**

**Camory – Premium Cookie Boutique**  
 167 Sisowath Quay, Tel: 023 224 937  
 www.camoryfoods.com  
 Makes cookies using agricultural produce from the provinces such as cashew nuts from Kampong Cham and Monduliri honey. A portion of the profits helps fund education for a local orphanage. Open 9am to 8.30pm.

A colourful shop with unique products designed by Mith Samlanh/Friends students and parents of former street kids. Range includes clothes, necklaces, purses and 2nd hand goods. Also has a nail bar run by students from the beauty class. Open from 11am to 9pm 7 days.

**Comme a la Maison**  
 13 Street 57, Tel: 023 360 801  
 Decidedly sophisticated French restaurant with a beautiful outdoor terrace area at the front, yet secluded from the street. Small delicatessen and bakery at the back of the restaurant. Open from 6am to 10.30pm.

**NYEMO**  
 14 Street 310, Tel: 023 213 160  
 NGO handicraft store on the grounds of Le Rit's training restaurant. Fun, funky and a bit different to the norm, their silks and accessories are in fantastic bright colours. Also has a great range of children's toys and hanging butterfly and bird mobiles. Second outlet on the eastern edge of the Russian Market.

**Dan's Meats**  
 51A Street 214, Tel: 012 906 072  
 Phnom Penh's man of meat, Lanzi, supplies his strictly non-vegetarian products to many of the restaurants and bars around town. A good range of quality products is for sale at his butcher's shop.

**Sayon Silk Works**  
 40 Street 178, Tel: 023 990 219  
 www.sayonsilkworks.com  
 Since 2001 self-taught Cambodian designer Sayon has created all her own handbags, cushions, scarves and quilts from Cambodian silk. A nice selection of goods on sale. Open from 9am to 7pm.

**Kurata Pepper**  
 Cnr. Streets 63 & 322, Tel: 023 726 480  
 Selling organic Koh Kong pepper and associated products, Kurata is one of the more unusual shops in town. Watch the workers shift through the peppercorns in a room near the front entrance.

**Silk & Pepper**  
 33 Street 178 & Amanjaya Hotel  
 Range of contemporary silk home interior products inspired by Asian and western designs. Sells all kinds of tailor made silks and linens. Also sells Kampot pepper. Open daily from 8.30am to 7pm.

**Madeleines Bakery**  
 19 Street 228 Tel: 012 988 432  
 A bakery and restaurant offering a variety of baked goods as well as organic lunches and catering services. Open Monday to Saturday 8am to 5pm

**Sobhana Boutique**  
 24 Street 144/49, Tel: 023 219 455  
 A not for profit organisation founded by Princess Norodom Marie, offering a range of colourful, handwoven silk products. Profits help to support local women by funding the training, medical care and education of weavers.

**Smokey da Boar**  
 Tel: 012 836 442  
 Kiwi run wholesale butchers specialising in sausages, ham on the bone and burger meat. Phone orders only.

**The Deli**  
 13 Street 178, Tel: 012 851 234  
 Café and bakery with a good range of take away breads, sandwiches and pastries. Now has a second outlet on Street 51. Open from 6.30am to 6.30pm, delivery service (within 30 minutes) is only from 7am to 11pm.

**Veggy's**  
 23 Street 240, Tel: 023 211 534  
 One of the few shops catering for western tastes – marmite, Branston pickle, cereals, Barilla pasta, Lao coffee and other expat essentials. Good range of cheeses, salad and meats are stored in the walk-in cold room at the back. Open 8am to 8pm.

**Wine**  
**Celliers d'Asie**  
 635 National Road 5,  
 Tel: 023 986 350  
 Wine supplier with the largest quantity of retail stock in town, the Celliers d'Asie group has been providing wine to most of the top hotels and restaurants in town for over ten years.

**Open Wine**  
 219 Street 19, Tel: 023 223 527  
 Aircon wine shop and tasting gallery. Sells wines, severac and calvados and meat. Has occasional free wine-tastings.

**Quarto Products**  
 30 / 31 Street 108, Tel: 023 221 772  
 email: yuthana@quarto-products.com  
 Fine food and wine distributors with large range of wines from around the world. Arranges frequent wine dinners and events.

**Red Apron**  
 15 Street 240, Tel: 023 990 951  
 Home of wine enthusiasts in Phnom Penh is both a wine boutique and tasting gallery. With around 300 wines the boutique has far more range for a special occasion than the supermarkets. 🍷

**silks & accessories**  
**Couleurs d'Asie**  
 33 Street 240, Tel: 023 221 075  
 www.couleursd'asie.net  
 Aircon shop selling French-designed silk and linen bags, scarves, cushions, pillow cases and quilts. Has a selection of soaps and bath salts from Senteurs d'Angkor, Amata beauty products and Eric Raisina's unique textiles and clothing. Open Mon.-Sat. 9am to 7pm, Sun. 9am to 3pm.

**Friends 'n' Stuff**  
 13 Street 215, Tel: 023 426 748



Phnom Penh is now home to a beautiful new **SÔNG** store - located in # 75 street 240; the store contains a full slice of **SÔNG** life: Holiday inspired clothing, Yoga & Lounge wear, Bags & Accessory for every occasion, as well as Home furnishings and Bed linens.

Like the Tropical Garden where they are created, the **SÔNG** collection grows organically and allow **SÔNG** follows a constantly evolving supply of new pieces for the home or family wardrobe.

Designer Valerie Gregori McKenzie inspiration comes from the time spend between her Nevis island home in the West Indies & her tropical Indochina style house on the Saigon river. Her designs are relaxed, yet sophisticated with beautiful hand made Embroidery.

Collections have evolved to become a true Life Style Brand with its heart & soul bound to the notion of healthy living and inner calm.

**SÔNG** collection are distributed in 22 countries, from five stars Spas & Resorts throughout the Maldives, Europe and the Caribbean to major luxury retailers such as SAKS 5th Avenue in the US and David Jones in Australia.

**SÔNG** Gresort.com  
 song.pp@asiasongdesign.com  
 SÔNG-life.com

**SÔNG**  
 Natural lifestyle by Valerie Gregori McKenzie





## The Hot Seat: Over a hot flame

Since it's the time of year for candle-lit romance, we thought we'd sit down with Cambodia's only eco-friendly candle maker, **Jimmy Campbell**.

### AsiaLIFE: What brought you to Cambodia and why did you stay?

**Jimmy Campbell:** I came initially when I was offered a job to manage the FCC in Phnom Penh in 1994.

The city was very different then, less traffic, more guns but equally as chaotic. I started work in June of that year and that marked the start of my love affair with Cambodia. There is something about this place that is addictive. It might be its people or its past or that it's changing quickly yet some of it is not changing much at all. I like those contrasts. It's a young growing country yet it is steeped in history. The thing I like best about it is that no two days are the same, everyday here is a challenge.

### What inspired you to start producing environmentally sound candles?

I have always loved candles and particularly loved the free flowing patterns that hot candle wax can make. I love the way the hot wax finds its own way and am intrigued by the mix of colours and scents. At a certain point I was between ventures and had time on my hands. It was then that I had the idea to make my own candles.

One of the things that put me off this idea was that paraffin was widely used in producing candles. Paraffin is the crudest part of oil that's left in the bottom of the barrel after they have refined it to make petrol, plastics etc. It's extremely toxic. I didn't want to be using it or burning it in my home or work place. I read about soy wax and immediately got inspired to make candles that were non-toxic and environmentally friendly.

### Tell us a bit more about your candles

Soy wax candles are non-toxic and burn at least 50% longer than normal paraffin candles.



**An eco friendly flame**

All of our candles are individually hand-poured, each one is different and unique.

Soy wax burns differently from normal paraffin candles therefore they have to be in a container. I use mostly glass containers as I like the look of the clear finish.

One of the great things about Soy wax is as it is bio-degradable, when the candle is finished the glass can be washed out with soapy water and used again.

Our glass containers can be reused as a glass, refilled again with Soy wax at a 10% discount, or we can buy it back from you for US\$1.

### What types of essential oils do you use in your candles?

I use a variety of fragrances and essential oils, the most popular are lemongrass, citronella, frangi-

pani, lavender and vanilla. The most unique fragrance we use is Bergamot, which is a small roughly pear-shaped fragrant citrus fruit that smells slightly floral.

### Any plans to expand?

The business is in its infancy so I will see where it goes this year.

I'd like to expand the business to Siem Reap later this year. We are the only business making these candles in Cambodia so it is possible for us to expand and give more jobs to Khmer people. One of my aims is to be able to put some profits toward a project that would put a solar panel in schools throughout Cambodia to provide electricity that could be used for evening classes to further education.

### How much do your candles cost and how can we get our hands on them?

The smaller candles burn for 29 hours and retail for US\$7, the larger ones burn for 46 hours and retail for US\$12. They are sold in I-Ching, Beyond Interiors, Orange River, Waterlilly, Ambre and Amatak Spa. Contact [karmacandles@hotmail.com](mailto:karmacandles@hotmail.com) for further details. 

## CV

**Jimmy Campbell**

**Company:** Karma Candles

**Position:** Operations Manager

**Nationality:** Scottish

**First came to Cambodia in:** 1994

# business

## advisory services

### Alcoholics Anonymous

20B Street 286, Tel: 092 974 882  
www.aaphnompenh.org  
AA meets on Friday at 7pm, Wednesday at 12pm and Sunday at 12pm.

### Narcotics Anonymous

20B Street 286, Tel: 012 990 937  
Meet every Monday at 8pm, Thursday at 8pm and Saturday at 7pm.

## Architecture & Design

### Architecture in Asia

Bassac Garden City, Street E Villar E10 (off Norodom Blvd.) Tel: 012 221 348  
Architect with 15 years of experience in interior and architectural design in Asia.

## bikes & mechanics

### The Bike Shop

31 Street 302, Tel: 012 851 776  
www.phnompenhbike.com  
Specialises in repairing trusty steeds as well as renting them out in the first place. Also provides dirt bike tours.

### Dara Motorbike Shop

339 Street 110, Tel: 012 335 499  
More of an off-road bike specialist, which also arranges Sunday trips into the wild.

### Emerald Garage

11 Street 456, Tel: 023 357 011  
Mechanics specialising in maintenance and repair of vehicles, including oil changing and body painting. The place to go if you want to buy a jeep.

## building

### Bizzy Beez

Tel: 012 755 913

Company that promotes itself as the city's premier handyman service. Does renovations, construction work, electrics, plumbing, painting and landscaping, as well as general handyman work.

## business groups

### Australian Business Association of Cambodia (ABAC)

9 Mao Tse Tung Blvd, Tel: 023 215 184  
www.abac.com.kh

### British Business Association of Cambodia (BBAC)

124 Norodom Blvd, Tel: 012 803 891  
senaka.fernando@kh.pwc.com

### Chambre de Commerce

Franco-Cambodgienne  
Office 13A Ground Floor  
Hotel Cambodiana, Tel: 023 221 453  
www.cccambodge.org

### International Business Club of Cambodia

56 Sothearos Blvd, Tel: 023 210 225  
zirconium@online.com.kh

### Canadian Trade

Commissioner Service Canadian Embassy,  
9 Street 254, Tel: 023 213 470 Ext 417  
www.infoexport.gc.ca/kh/

### BCC / Malaysian Business Council of Cambodia

Unit G21, Ground Floor, Parkway Square  
113, Mao Tse Tung, Tel: 023 221 386  
mbcc.secretariat@gmail.com

### Singapore Business Club (Cambodia)

92, Norodom Blvd, Tel: 023 360 855  
singcamb@online.com.kh

## commercial banks

### Advanced Bank of Asia

148 Sihanouk Blvd.,  
Tel: 023 720 435  
www.ababank.com.kh  
Commercial bank, managed by Koreans and Cambodians, established in 1996. Has branch office on Mao Tse Tung.

### ANZ Royal Bank

Main Branch, 20 Street 114  
www.anzroyal.com  
Cambodia's major commercial bank has brought international standards of banking to the country. Has a large number of ATM machines around Phnom Penh and can arrange money transfers.

### Maruhan Japan Bank

83 Norodom Blvd.,  
Tel: 023 999 010  
First Japanese commercial bank in Phnom Penh.

## insurance

### AG Insurance

Franco Cambodiana,  
313 Sisowath Quay Tel: 012 195 35 85,  
info@ag-service.org  
Professional insurance company offering health, home, car, factory, employee and hotel insurance packages.

### Asia Insurance Cambodia

5 Street 13, Tel: 023 427 981  
email@asiainsurance.com.kh  
www.asiainsurance.com.kh  
Hong Kong-based insurance company registered in Cambodia in 1996. Offers all types of insurance services.

### Forte Insurance (Cambodia)

325 Mao Tse Tung,  
Tel: 023 885 066  
www.forteinsurance.com  
The largest Cambodian underwriters. Established in 1996, specialise in car, accident, property, personal liability, marine, travel and transport insurance.

### Infinity Insurance

126 Norodom Blvd,  
Tel: 023 999 888  
Professional insurance company offering motor, property, home, marine cargo, personal accident, healthcare, construction and engineering insurance. Group policies can be customised.

## international schools

### ICan International School

85 Sothearos Blvd,  
Tel: 023 222 418  
www.ican.edu.kh  
International school teaching the English national curriculum to over 230 pupils. Has spacious and modern facilities.

### International School of Phnom Penh

146 Norodom Blvd,  
Tel: 023 213 103  
www.ispp.edu.kh  
Not-for-profit international school founded in 1989, ISPP has 395 students from pre-school to Grade 12. It is the largest international school in Cambodia, and the only authorized IBO school in the country.

### Northbridge School

1km off National Road 4 on the way to the airport, Tel: 023 886 000  
www.niscambodia.com  
info@niscambodia.com

Quality international school with curriculum for students from pre-school to high school as well as good sports facilities.

### Zaman International School

2843 Street 3, Tel: 023 214 040  
www.zamanisc.org  
International school that teaches a full curriculum to children from four to 18. Facilities include basketball and volleyball courts, a football field and a science lab.

## it & software

### Conical Hat (Cambodia) Ltd.

Norodom Blvd., Tel: 023 362 957  
info@conicalhat.com, conicalhat.com  
Software company that specialises in providing highly localised business solutions including accounting, payroll and billing.

## legal

### Sciaroni & Associates

56 Sothearos Blvd., Tel: 023 210 225  
Law firm with a good reputation. Just the ticket if you get into a spot of bother.

## Post Office

Main Post Office  
Cnr. Street 102 & Street 13  
Open from 6.30am to 9pm

# PHOTOGRAPHIC DAY TRIPS



## GET OUT OF TOWN!

MORNING PRACTICAL CLASSES IN PHNOM PENH

AFTERNOON GUIDED TOURS TO PLACES YOU HAVEN'T BEEN

BEFORE

092 526 706

WWW.NATHANHORTONPHOTOGRAPHY.COM

# Embassies

### Australia

Villa 11 Street 254, Tel: 023 213 470

### Belgium

Phnom Penh Center, Sihanouk Blvd., Block/entrance F - Floor 7  
Tel: 023 214 024

### Canada

Villa 11 Street 254  
Tel: 023 213 470

### China

156 Mao Tse Tung Boulevard  
Tel: 023 720 920

### Denmark

8 Street 352 Tel: 023 987 629

### France

1 Monivong Boulevard  
Tel: 023 430 020

### Germany

76-78 Street 214 Tel: 023 216 381

### Japan

75 Norodom Boulevard  
Tel: 023 217 161

### Laos

15-17 Mao Tse Tung  
Tel: 023 983 632

### Malaysia

5 Street 242 Tel: 023 216 176

### Myanmar

181 Norodom Boulevard  
Tel: 023 223 761

### Philippines

33 Street 294  
Tel: 023 215 145

### Singapore

92 Norodom Boulevard  
Tel: 023 221 875

### Sweden

8 Street 352 Tel: 023 212 259

### Thailand

196 Norodom Boulevard  
Tel: 023 726 306

### United Kingdom

27-29 Street 75  
Tel: 023 427 124

### United States

1 Street 96 (Wat Phnom)  
Tel: 023 728 000

### Vietnam

436 Monivong Boulevard  
Tel: 023 726 283



# Trevor Keidan: You Know You Need a Financial Adviser When...



WHEN IT COMES TO personal finance, going it alone has never been easier. Planning, budgeting, trading and monitoring of investments have all been brought home to the individual through the internet, the mobile phone and even TV. Thousands of books are on the subject, not to mention scores of software applications – and they are all designed to enrich our bank balances and ultimately our lives. But are they really a good thing?

**■ GOING IT ALONE**  
 During the 90s online brokers appeared to be all the rage. There were even those who traded in their day jobs for day-trading – buying and then selling stocks, currencies, commodities and other financial products, all in the same day in the hope of making a quick profit. Do-it-yourself investors used the internet to research, pick and trade their own stocks. Drawn in by the ease and accessibility of online trading, many of them lost their shirts.

Living in an age when real time stock prices, affordable online brokers and accessible research are all available at the touch of a button, there is no doubt that such hi-tech convenience can be tempting.  
 If you are thinking of going it alone, I advise caution. Remember you know you need a personal financial adviser when you:

- **LOST A LOT OF MONEY IN THE DOT COM BOOM AND BUST IN THE 1990S;**  
 Think day-trading is an easy and quick way to make money; Start believing every analyst and every pundit you see on financial news programmes on television – and you are willing to invest in every stock they talk about;
- **THINK YOU'VE DISCOVERED THE NEXT BIG THING – ANOTHER MICROSOFT – AND YOU ARE TEMPTED TO SPEND EVERY CENT YOU OWN BUYING THE COMPANY'S SHARES;**  
 Think that if you invest in the stock market for a few months you can make a quick 'killing';
- **THINK PICKING SUCCESSFUL STOCKS AND WINNING INVESTMENTS REQUIRES LITTLE WORK AND IS EASY.**

**■ DO YOU NEED PROFESSIONAL HELP?**  
 All joking aside there are some serious signals that might indicate you need a hand when it comes to sorting out your personal finances.

- **YOU ARE SURVIVING ON CREDIT?**  
 If you are reliant on your credit cards to make ends meet and are unable to save or pay bills on time then it might be time to hand over your financial planning to someone else.  
 You live from wage-check to wage-check  
 If you are totally reliant on your wage-check to meet all your monthly costs, and have no financial contingency plan to fall back on if you lost your job, then it might be time to seek financial advice.  
 You have no retirement plan  
 If you have absolutely no idea what your retirement will be like and what you would need to live on after you retire, then you might need to engage a financial adviser.

- **YOU HAVE JUST EXPERIENCED A MAJOR CHANGE**  
 If you have just had children, got married or started your own business, then you might need a financial planner to prepare for the future.  
 You are undisciplined  
 You find it impossible to save and you find it very easy to 'blow' all your money without any thought of your plans for the future. You might need a financial adviser to keep yourself and your plans on track.
- **BE REALISTIC**  
 Remember that financial advisers are not magicians. They are there to protect you from yourself and your wild financial impulses. They should come up with a comprehensive financial plan that dictates what you will do with your money, help you to define your financial objectives, and suggest ways and means to achieve them. Finally if your financial adviser uses the phrase "you can bet your house on it" – look for either another adviser or a new house. 🏠



+855.12.899.325 :: Phnom Penh, Cambodia, Earth  
 keithakelly@gmail.com :: www.keithakelly.com

# ATMs

## ANZ Royal

### ANZ Royal Branch ATM

#### Accessible Time:

#### 24 hours

- ANZ Royal Independence Monument Branch. 100 Sihanouk Blvd.
- ANZ Royal Main Branch: 20 Fe-Eo, Kramuon Sar, Corner of Street 67
- ANZ Royal Olympic Branch: 361-363 Sihanouk Blvd.
- ANZ Royal Pet Lok Sang Branch: 1A & 1B Street 271
- ANZ Royal Phsar Derm Thkov Branch: 616A & B Street 271
- ANZ Royal Riverside Branch: 265 Sisowath Quay
- ANZ Royal Teuk Thla Branch: 1Eo & 1E1, Street 110A

### ANZ Royal Offsite ATM

#### Accessible Time:

#### 24 hours

- ANZ Royal: 14 Street 106
- Big A Supermarket: 226-272, Monivong Blvd.
- Caltex Pet Lok Sang: Russian Blvd., Cnr. Street 271
- Flamingos: 32 Street 172
- Hotel Cambodiana: 313 Sisowath Quay
- PPIA-Arrival Luggage Pickup: Phnom Penh International Airport
- PPIA-Cafe Select: Phnom Penh International Airport
- PPIA-International Departure: Phnom Penh International Airport
- Rock Entertainment: 468 Monivong Blvd.
- Street 271: No. A81 Street 271
- Total Avenue De France: Avenue De France
- Total Monivong: Corner of Monivong Blvd and Street 310
- Caltex Boeung Keng Kang: Norodom Blvd, Cnr. of Street 41
- Caltex Boeung Tra Bek: Cnr. of Monivong Blvd. and Street 474
- Caltex Bokor: Cnr. of Monivong and Mao Tse Tung Blvd.
- Caltex Calmette: Cnr. of Monivong Blvd. and Street 86
- Caltex Mondial: Corner of Mao Tse Tung Blvd. and Street 202
- Caltex Phsar Derm Kor: Cnr. of Monireth Blvd., 374 and 384
- Caltex Sokha: Cnr. of Kampuchea Krom Blvd. and Street 139
- Caltex Spark: Cnr. of Mao Tse Tung Blvd. and Street 167
- Total Chateau D'Eau : Sihanouk Blvd.
- Total La Deese: Cnr. of Street 182 and 169
- Total La Gare: Cnr. of Russian Blvd. and Street 108
- Total Phsar Thmey: Cnr. of Street 217 and 316
- Total Takhmao: National Road 2, Sangkat Chak Angre Krom, Khan Mean Chey

### ANZ Royal Offsite ATM

#### Accessible Time:

#### 5.30am to 10.30pm

- Royal Guest House: 91Eo, Street 154

### ANZ Royal Offsite ATM

#### Accessible Time:

#### 8am to 9pm

- Happy Market: 268, Street 182, Tuol Kok
- Lucky Seven Phnom Penh Centre: Cnr. of Sihanouk Blvd. and Street 274
- Lucky Super Market: 160, Preah Sihanouk Blvd.
- Lucky Water Tower: No 37-39 Monireth Blvd.
- Paragon Supermarket: 12 Street 214

### ANZ Royal Offsite ATM

#### Accessible Time:

#### 9am to 9pm

- Pencil Norodom: 15 Street 214
- Pencil Supermarket- Riverside: Sisowath Quay

### ANZ Royal Offsite ATM

#### Accessible Time:

#### 9am to 12am

- The Tamarind: 31 Street 240

### ANZ Royal Offsite ATM

#### Accessible Time:

#### 6am to 7pm

- Meeting Café: 12E, Russian Blvd. and Street 215

### ANZ Royal Offsite ATM

#### Accessible Time:

#### 6am to 10.30 pm

- Lucky Bright Restaurant: H5 Norodom Blvd.
- Seven Bright Restaurant: 6 Street 13, (Opposite Post Office)

### ANZ Royal Offsite ATM

#### Accessible Time:

#### 7am to 9.30pm

- Lucky Burger Monivong: 219 BC, Monivong Blvd.
- Top Ocean Burger: 103 Street 184

### ANZ Royal Offsite ATM

#### Accessible Time: 7am to 9pm

- Asia Europe University: 832 Kampuchea Krom
- Parkway Square: 113 Mao Tse Tung Blvd.

### ANZ Royal Offsite ATM

#### Accessible Time:

#### 8am to 10pm

- U-Care Pharmacy Phnom Penh: Cnr. Street 178 and Sothea Blvd.

### ANZ Royal Offsite ATM

#### Accessible Time:

#### 7am to 10pm

- Angkor Thom Book Centre: 261, Kampuchea Krom Blvd., Toul Kok

### Cambodian Public Bank

- 23 Street 114

### Canadia Bank

- 126 Charles de Gaulle Blvd.
- 265-269 Ang Duong
- 394 Sihanouk Blvd.
- Royal Phnom Penh International Airport
- Sorya Shopping Centre, 16-61 Street 63

### SBC Bank

- Head Office, 68 Street 214
- 203 Monivong Blvd.
- 168 Street 215
- 327 Sisowath Quay
- 55 Sihanouk Blvd.

The place to go if you want to send something overseas.

## Printing & Design

### Digital Advertising

60E Street 38, Tel: 023 987 600  
Print house with modern equipment that provides full print services as well as graphic design.

## Relocation

### Crown

115-116 Street 335, Tel: 023 881 004  
Global transportation and relocation company with over 150 offices in 50 countries, specialising in expat support and household shipment.

## Security Firms

### MPA

23 Street 214, Tel: 023 210 836  
Well-established security company that is responsible for keeping many of the

town's buildings safe and sound.

## Shipping

### Crown

Hotel Cambodiana, 313 Sisowath Quay, Tel: 023 986 680, www.crownrelo.com  
Global transportation & relocation with over 150 offices in 50 countries, specialises in expat support and household shipment.

## Telecoms

### Cadcoms

825A Monivong Blvd., Tel: 023 726 680  
Communications company with Norwegian connections has launched the qb 3G entertainment network. Has competitive talk packages.

### Cambodia Samarat Communication

56 Norodom Blvd., Tel: 016 81001  
Internet provider that issues the 016 SIM card.

### Camshin

6B-7B 294 Mao Tse Tung Blvd. Tel: 023 367 801

Internet provider that also installs land lines and issues the 011 SIM card.

### City Link

170 Norodom Blvd., Tel: 023 220 112

One of the major internet providers in Phnom Penh.

### Ezecom

7D Russian Blvd., Tel: 023 888 181

www.ezecom.com.kh

Internet service provider that promises boundless internet packages suited to everyone's needs. Good packages for those looking for unlimited downloads.

### Hello

Tel: 016 810 000, www.hello.com.kh

Mobile phone provider that has the 015 and 016 SIM card. Is currently promoting cheap overseas calls.

### Mobitel

33 Sihanouk Blvd., Tel: 012 801 801  
Largest ISP in the country. Major mobile phone company which issues the 012 SIM card.

### Online

60 Monivong Blvd., Tel: 023 727 272

The biggest and most reliable of the internet providers. Watch out for their hotspots around town.

### Star-Cell

173 Nehru Blvd., Tel: 023 888 887  
Newest of the mobile phone providers in the capital. Has recently established an office within Siem Reap too. Issues the 098 SIM card.

### TeleSurf

33 Sihanouk Blvd, Tel: 012 800 800

www.telesurf.com.kh  
Internet service provider (ISP) providing 24-hour broadband internet service. 

# Airlines



- |  |   |
|--|---|
| <p><b>Air Asia</b><br/>66 Mao Tse Tung Boulevard<br/>Tel: 023 356 011</p> <p><b>Angkor Airways</b><br/>32 Norodom Boulevard<br/>Tel: 023 222 056</p> <p><b>Bangkok Airways</b><br/>61A Street 214<br/>Tel: 023 722 545</p> <p><b>China Airlines</b><br/>32 Norodom Boulevard<br/>Tel: 023 222 393</p> <p><b>Dragon Air</b><br/>168 Monireth Boulevard<br/>Tel: 023 424 300</p> <p><b>Eva Air</b><br/>298 Mao Tse Tung Boulevard<br/>Tel: 023 219 911</p> <p><b>Jet Star Asia</b><br/>333B Monivong Boulevard<br/>Tel: 023 220 909</p> <p><b>Lao Airlines</b><br/>58C Sihanouk Boulevard<br/>Tel: 023 216 563</p> | <p><b>Malaysia Airlines</b><br/>172 Monivong Boulevard<br/>Tel: 023 218 923</p> <p><b>Royal Air Services</b><br/>168 Monireth Boulevard<br/>Tel: 023 881 090</p> <p><b>Royal Khmer Airlines</b><br/>36B Mao Tse Tung Boulevard<br/>Tel: 023 994 502</p> <p><b>Shanghai Air</b><br/>19 Street 106<br/>Tel: 023 723 999</p> <p><b>Siem Reap Airways</b><br/>61A Street 214<br/>Tel: 023 722 545</p> <p><b>Silk Air</b><br/>313 Sisowath Quay (Himawari Hotel)<br/>Tel: 023 426 808</p> <p><b>Thai Airways</b><br/>294 Mao Tse Tung Boulevard<br/>Tel: 023 214 359</p> <p><b>Vietnam Airlines</b><br/>41 Street 214<br/>Tel: 023 363 396</p> |
|--|---|

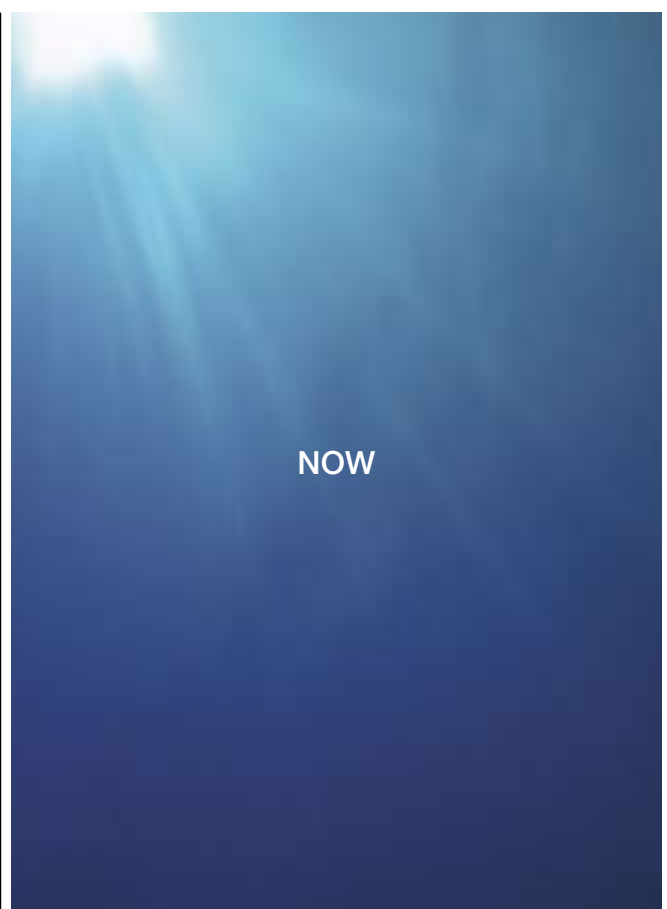

NOW



Your  
"Home" away from Home



## The Comforts of Home and Much More...

Asia Club Boutique Hotel, luxurious home away from home, offers guests an extraordinary tranquil place that is created by combining unique architecture and structure, expressive decor and artistry, and magnificent features all in one great location. With our beautiful garden and great service, the result is an extraordinary experience that would make your memory a long and lasting one. Make your long-term stay reservations with selections of Khmer Bungalow and Khmer Villa, and enjoy the culture of Cambodia just like at home.

## Features & Amenities

Our suites feature Khmer-Style queen bed or double beds, full bathroom, as well as the standard business services and amenities including: flat screen television, premium bath essentials, lighted makeup mirror, hair dryer and scale, full-size executive writing desk, fully stocked refreshment bar, in-room safe, daily housekeeping attention, complimentary morning newspaper, high-speed Internet access and WI-FI in the vicinity, 24-hour reception, 24-hour security and video surveillance, and parking lot.



Address: No.456A, Monivong Blvd.(st93), Phnom Penh, Cambodia  
HP: 023 721766, 011 896 286

Website: [www.asiagarden.com.kh](http://www.asiagarden.com.kh)  
Email: [info@asiagarden.com.kh](mailto:info@asiagarden.com.kh)

## Getaway: Gateway to the Cardamoms

Two and a half hours up the Pi Phat River from the bridge at Andoung Teuk lies the relatively undiscovered village of Chi Phat. Known to some as the Gateway to the Cardamoms, this emerging destination offers a refreshing alternative to the well-trodden tourist paths throughout Cambodia. Words and Photos by **Kate Burbidge**.



Tranquility settles on the Cardamoms

AN INTERNATIONALLY recognised bio-diversity hot-spot, the Cardamom Mountain Range is home to more than half of Cambodia's 23,000 plant species, over 200 bird species and 14 species of globally threatened mammals. It is also one of the few remaining elephant corridors and large predator ranges in the region.

As recently as the 90s the area suffered from illegal logging, poaching and unsustainable farming practices. Driven by poverty, the locals were offered little alternative to these environmentally damaging activities in a remote rural area where, until recently, tourism was unknown. Now things are slowly starting to change.

### ■ COMMUNITY-BASED ECO-TOURISM

Set up in January 2007, Chi Phat's community-based eco-tourism (CBET) project runs tours for those seeking a supplement to the usual tourist diet of temples and beaches.

Two- or three-day treks through the forest offer the chance to see some of the area's diverse wildlife or visit an ancient burial-jar site. Mountain-bike tours are an alternative way to visit local sites of interest, the trails are varied and challenging but not for the complete novice. The bat cave, waterfalls and the sunrise bird-watching boat trip all present some wonderful photo-opportunities.

The Chi Phat CBET tour mixes the chance of experiencing the local wildlife with witnessing a community moving towards a more sustainable livelihood and a higher standard of living.

### ■ BIRD WATCHING

The Boys' Own Adventure begins at dawn. There's just about time to grab a cup of "the best drip-coffee in the world" before, complete with hammock, blanket and binoculars, you board the boat for the bird watching trip. This early start affords some stunning misty-pink sunrise photography before the birds in question are properly awake.

Breakfast is served a couple of hours upstream where you transfer from motorboat to smaller rowing boats. This allows you to get up close to the birds without scaring them off. Macaques and squirrels can be spied alongside hornbills in the high branches. Even if the local fauna is playing hard to get, the trip is worth it for the peace and scenic beauty alone.

### ■ TWO-DAY HIKE

The 30-kilometre, two-day hike follows old hunting and logging trails to avoid further impact on the forest. Winding through secondary forest – the primary jungle has long since been logged





Rollin' on the River

out – full of exotic sights, scents and sounds you get the impression of being somewhere new and far from the norm. If you are very quiet, between 10.30am and 11am you can hear the distant, lilting song of the gibbons high in the tree tops.

The hike itself requires a moderate to good level of fitness. The going is not particularly arduous but even in the shade of the forest it gets hot, so plenty of water is required. The fairly rough terrain requires good awareness of what you're walking through or clambering on. There are, however, regular breaks for water, food and rest.

Occasional breaks in the forest reveal traditional wooden and thatched houses with at least one small boat in evidence – a reminder that the river is not only a source of food but the main transport route for the locals.

Although the guides do their best to answer any questions, they could do with being more forthcoming with unsolicited information.

The trail eventually leads up to an open grassy area that hosts a watering hole in wet season. At dusk and dawn it's possible to see and hear hornbills, parrots, wild pigs and monkeys.

The campsite is very low impact. Wooden poles are fixed in the ground and hammocks are strung between them. Tarpaulin is tied to the taller poles to provide protection from the morning dew. The hammocks are strung close – the body heat of your neighbours being vital during the very cold jungle night. It's all great-outdoors fun though and

the hammocks are surprisingly comfortable. The next morning's very welcome breakfast is guaranteed to be the best you've tasted.

Towards the end of the hike is a stretch that reminds you why you came here. The countryside is parched and open, sandy, grassy lowlands, sparse trees, burnt patches still evident – this too used to be forest. These are the past mistakes that the CBET project is aiming to correct. It's why Chi Phat needs sustainable alternatives.

#### ■ GETTING THERE

To reach Andoung Teuk take a bus, minibus or shared taxi towards Koh Kong on Highway 48. Once you get there negotiate with the boatmen for a relaxing two- to three-hour trip up-river to Chi Phat, usually around 10,000 riel per person. The boat journey is a good way to unwind and have your first view of the local countryside.

#### ■ ARRANGING YOUR TRIP

The CBET office is the place to go to organise anything in Chi Phat. This is where you eat, book your guesthouse, rent a bicycle or mountain-bike and helmet, hire basic hiking equipment, find a moto. They provide the hammocks, nets and blankets, guides and cooks for your hikes and mountain-bike rides. It's the place to be in Chi Phat.

#### ■ FOOD

The food provided by CBET was unexpectedly (given the location and very basic facilities) good. The local cuisine is simply

presented and delicious – curries, soups, prawns, chicken, papaya salad, rice and even some of the best chips in the country. The meals served on the trek are basic but well cooked – rice and egg are the staples, but what eggs! Somewhere between poached and fried they are the

best thing to wake up to in the chill of a jungle morning.

#### ■ ACCOMMODATION

Accommodation reflects the same basic but sound standards, the guesthouses are clean and the beds comfortable. You stay in traditional wooden family houses. The village has no mains facilities for water, electricity or sewerage, so the facilities (scoop showers and squat toilets) are shared and the water is somewhat bracing, particularly at 5am before the bird watching trip! However, if you want Le Royal luxury you wouldn't be here, would you?

#### ■ SUGGESTED EQUIPMENT FOR TREKS

Good walking shoes and socks, head-torch, long trousers, long-sleeved shirt, pullover / fleece, sunscreen, insect repellent, hat, sunglasses, krama / sarong, silk hammock-liner, basic toiletries.

For further information visit the following websites:  
[www.livelearn.org](http://www.livelearn.org)  
[www.wildlifealliance.org](http://www.wildlifealliance.org)  
[www.mountainbikingcardamoms.com](http://www.mountainbikingcardamoms.com) 

## Chi Bat 101



Tourism in Chi Phat has been developed and is administered by the CBET project. Facilitated by Wildlife Alliance and led by the Chi Phat CBET committee, the project seeks to counter the effects of illegal logging and wildlife trading in the area by helping villagers identify and develop alternative sustainable livelihoods that protect, conserve and strengthen their fragile environment.

Chi Phat commune consists of four villages and 550 families, most of whom are willing participants in the project. Over a hundred families are directly employed as service providers – guides, rangers, motodops, boatmen, cooks, and guesthouse or homestay providers. Fees generated by tourism are divided between the service provider and a commune fund administered by the Chi Phat CBET committee. 

# phnom penh: central



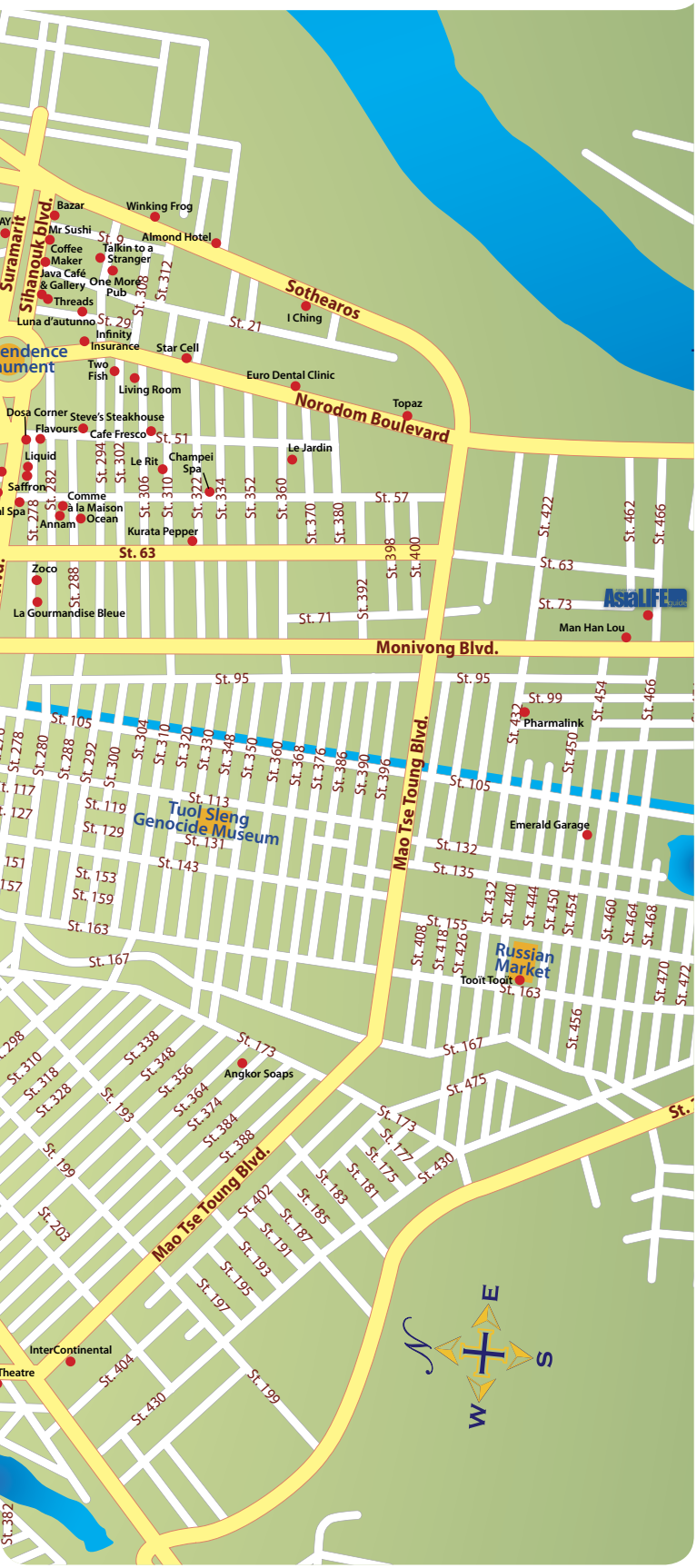

THINK OF OUR  
**MALT, HOPS  
 & YEAST**  
 AS SUCCESSFUL  
 BUSINESS PARTNERS.

ENJOY WINNING

## getaway

ChildSafe®



A network protecting children from all forms of abuse. [www.childsafe-cambodia.org](http://www.childsafe-cambodia.org).

## battambang

## La Villa

East bank of river, Tel: 012 826 186  
[www.lavilla-battambang.com](http://www.lavilla-battambang.com)  
Beautifully restored 1930s colonial house with six rooms.

## Riverside Balcony Bar &amp; Restaurant

West bank of river, Tel: 012 437 421  
Traditional wooden house with great views of the river and good food. Open from 4pm to midnight.

## chau Doc (vietnam)

## Victoria Chau Doc Hotel

32 Le Loi, Tel: +84 76 865 010  
[www.victoriahotels-asia.com](http://www.victoriahotels-asia.com)

A few kilometres on the Vietnamese side of the border, Chau Doc's finest has great views of the Bassac River, a swimming pool, restaurant serving both international and Vietnamese cuisine and great massages.

## kampot

## Bar Red

Old Market area, Tel: 092 724 720  
Restaurant and bar in close to the river, just around the corner from Bokor Mountain Lodge. Open from 6pm to late this is a good spot for a late night drink with personable host Steve, or to try some Indian food including their gargantuan samosas.

## Blissful Guest House

Kampot, Tel: 012 513 024  
Small guest house, with 11 rooms, set in a quiet part of town. Downstairs restaurant and bar, and communal TV room upstairs.

## Bodhi Villa

Across the river, Kampot  
Small guest house just across the old bridge in Kampot. The few basic rooms are extremely cheap and there are bungalows overhanging the river too. Most definitely a place to chill like the lotus eaters.

## Bokor Mountain Lodge

Riverfront, Kampot, Tel: 033 932 314  
[www.bokorlodge.com](http://www.bokorlodge.com)  
Beautiful French colonial building situated on the riverfront with well-fitted air-conditioned rooms. Also has a good restaurant and bar with some outside seating overlooking the river.

## Epic Arts Café

Old Market, Kampot  
Employing deaf staff, this café next to the old market has a good range of bagels, shakes, brownies and coffee. Open from 7am to 6pm.

## Jasmine

House 25 Riverside Road, Kampot  
Tel: 012 927 313  
Run by the friendly Jasmine and her husband Mark, this café/restaurant is a stylish oasis on the Kampot riverfront. Serves tasty Thai, Khmer and café fare. Also has photography decorating the walls, and occasional film nights.

## Les Manguiers

2km north of Kampot, Tel: 092 330 050  
Small resort with bungalows and rooms set in beautiful gardens overlooking the river. Also has a restaurant with daily changing, freshly prepared food. Best to book up in advance especially at weekends.

## Mea Culpa

44 Sovansokar, Kampot, Tel: 012 504 769  
New accommodation established by the former manager of Bokor Mountain Lodge set in the French Quarter. Six rooms have air con, hot water, DVD and TV. The large garden has a patio pizzeria and bar.

## Rikitikitavi

Riverfront, Kampot, Tel: 012 274 820  
[rikikitavi@asia.com](mailto:rikikitavi@asia.com)  
Western food served in large portions in this river-facing restaurant, bar and three-room guesthouse. A more upmarket venue for Kampot, the upstairs seating affords great sunset views. Restaurant and bar closed on Mondays.

## Rusty Keyhole

Riverfront, Kampot  
This riverside British pub is the place for expats to chew the fat over a pint in town. Friendly British owner has created as close to the atmosphere of a rural pub as you can in Kampot. Live premiership games, sunset happy hour, daily BBQs and a strict 'no missionaries' policy make this a must. Open 8.30am to midnight.

## kep

## Beach House

Opp. Kep Beach, Tel: 012 240 090  
[www.thebeachhousekep.com](http://www.thebeachhousekep.com)  
Small hotel with pool in an excellent location, directly opposite Kep's mermaid statue. Relaxed café, and tasteful western-style rooms all with sea view. Can organise trips to nearby Rabbit Island or further afield to Bokor Mountain.

## Champey Inn Resort

Tel: 012 501 742  
Sea-fronted resort with fan-cooled bungalows. Has a swimming pool, a restaurant, a bar and a pleasant garden.



Colonial elegance at La Villa in Battambang

## Kep Lodge

Tel: 092 43 53 30 [www.keplodge.com](http://www.keplodge.com)  
Six nicely decorated, private bungalows with a big veranda, pool table, swimming pool and WiFi. Also has a bar and restaurant with Khmer and western food.

## Knaibang Chatt Resort

Tel: 012 879 486  
[www.knaibangchatt.com](http://www.knaibangchatt.com)  
Exclusive seaside resort just along from the crab stalls, which has opened up its doors to the public. Elegant swimming pool, air-con, gym, library and fantastic gardens, this resort is the ideal place to get away from Phnom Penh. Good restaurant with fantastic views of the sea. Check for special offers. Also has a Sailing Club next door with bar and restaurant, as well as hobby cats.

## Le Bout du Monde

Kep, Tel: 011 964 181  
[www.leboutdumondekep.com](http://www.leboutdumondekep.com)  
Individual and separate bungalows in traditional Khmer architecture located at a top of a hill with good views and nice gardens. Serves French and Khmer cuisine. Rooms have hot water, mini-bar, fan and safe.

## Led Zeppelin

At the roundabout, Kep  
Small bar which sells the coldest beer in town situated right by the Kep roundabout. Ambience is distinctly rustic but chill and the limited range of snacks great value.

## Star Inn

Kep Beach, Tel: 011 765 999  
Hotel overlooking Kep Beach that has good sized and elegant air-con rooms. Rooftop

## Golden Banana Boutique Resort

Opened December 2008

Waf Damnak, Siem Reap, Cambodia  
Tel: (855) 63 766-655 - (855) 12 654-638  
Email: [goldenbanana2@gmail.com](mailto:goldenbanana2@gmail.com)  
Website: [goldenbanana.info](http://goldenbanana.info)

## Le Bout Du Monde



Kep, Cambodia

Come and get some fresh air at our guest house "Le Bout du Monde" in KEP

Website: [www.leboutdumondekep.com](http://www.leboutdumondekep.com) tel: +855(0)11 96 41 81 mail: [contact.leboutdumonde@gmail.com](mailto:contact.leboutdumonde@gmail.com)

restaurant serves seafood and cocktails. It stays open to late at weekends.

**Veranda Natural Resort**  
Tel: 012 888 619, [www.veranda-resort.com](http://www.veranda-resort.com)  
Traditional wooden bungalows set in the hillside, some with fans and others with air con. Settle down for the night and listen to the jungle purr. Has a good restaurant and bar with some quite stunning sweeping views down to the coast.

**kratie**

**Cambodian Craft Co-operation**  
At Wat Roka Kandal  
Small craft centre selling wickerwork by local artisans, housed inside Wat Roka Kandal. Funded by a German chamber of trades and crafts. The baskets and handicrafts have marked prices.

**Le Relais de Chhlong**  
Mekong riverside, Chhlong (Kratie Province), Tel: 012 501 742  
[champpeyinn@mobitel.com.kh](mailto:champpeyinn@mobitel.com.kh)  
Beautifully restored colonial house set in a peaceful village with stylishly furnished rooms. Intimate restaurant, swimming pool and river views make this a unique and luxurious place to get away from it all.

**Red Sun Falling**  
Rue Preah Sumarit  
Well-established western-run café and bar on the riverfront. One of the few bustling places in the evening, it has tasty food with dishes in the US\$1.50-2.50 range.

**Star Guesthouse**  
Opposite the market, Tel: 012 753 401  
A hub for arranging transportation and getting travel advice on travel to Ratanakiri, this guesthouse has cheery, colourful and clean rooms. The café serves up some of the most innovative food and drink in town. Has facilities for storing motorbikes also available.

**phnom penh - deluxe**

**Amanjaya**  
1 Sisowath Quay, Tel: 023 214 747  
[www.amanjaya.com](http://www.amanjaya.com)  
Large hotel with a great central location along the river front. The rooms are spacious and well-equipped with tasteful Khmer decorations. The downstairs restaurant doubles up as the air-con K West bar.

**Cambodiana**  
313 Sisowath Quay, Tel: 023 426 288  
[www.hotelscambodiana.com](http://www.hotelscambodiana.com)  
Great riverside location with spectacular sweeping views of the confluence of three rivers. Large rooms with air-con, in-room safes and good bathrooms. Live band plays nightly (except Sundays).

**Himawari**  
313 Sisowath Quay, Tel: 023 214 555  
[www.himawarihotel.com](http://www.himawarihotel.com)  
The 115 beautifully-designed suites have aircon, cable TV, IDD, Internet, in-room safes and large bathrooms. Nice swimming pool and good gym facilities as well as two good tennis courts.

**Imperial Garden Hotel**  
315 Sisowath Quay, Tel: 023 219 991  
Large hotel and villa complex next to the Cambodiana. Has a swimming pool, gym and tennis court. Live band plays nightly.

**Intercontinental**  
296 Mao Tse Tung, Tel: 023 424 888  
[www.ichotelsgroup.com](http://www.ichotelsgroup.com)  
One of Phnom Penh's most luxurious 5-star hotels. The 346 air-con rooms have all the expected facilities including in-room safes and king size beds. Also has a large swimming pool, a Clark Hatch Fitness Centre, spa and beauty salon.

**Raffles Hotel Le Royal**  
Street 92, Tel: 023 981 888  
[www.phnompenh.affles.com](http://www.phnompenh.affles.com)  
Emanates the same class as its more famous namesake in Singapore. The Elephant Bar is a popular expat haunt during the 4pm to 8pm happy hour. Beautiful gardens with a separate swimming pool for kids plus reasonably priced apartments for long stays.

**Sunway Hotel**  
1 Street 92, Tel: 023 430 333  
[www.sunway.com.kh](http://www.sunway.com.kh)  
Luxurious international four-star hotel located close to Wat Phnom with 138 well-sized rooms. Spa, good business centre and meeting facilities.

**phnom penh - mid**

**Almond Hotel**  
128F Sotheaors Blvd, Tel: 023 220 822  
[www.almondhotel.com.kh](http://www.almondhotel.com.kh)  
56-room hotel located close to the Royal Palace and the riverfront with spacious rooms with WiFi. Downstairs restaurant serves dim sum and Cantonese food. Also has a spa.

**Anise**  
2C Street 278, Tel: 023 222 522,  
[www.anisehotel.com](http://www.anisehotel.com)  
Small hotel with well-fitted, good size rooms, all equipped with air-con, in-room safe and hot water. Downstairs restaurant serves Asian cuisine.

**Billabong**  
5 Street 158, Tel: 023 223 703  
[www.thebillabonghotel.com](http://www.thebillabonghotel.com)  
Centrally-located mini-hotel with a great swimming pool surrounded by beautiful palm trees. Serves good food. The rooms are a reasonable size with air-con.

**Bougainvillier**  
277G Sisowath Quay, Tel: 023 220 528  
Stylish riverfront hotel with 40 rooms, including some impressively large suites. Dark wood antique style furniture and jewel coloured silks create a luxurious ambience, and all the necessary amenities are available. The hotel is also home to a gourmet restaurant.

**FCC Phnom Penh**  
362 Sisowath Quay, Tel: 023 724 014  
[www.fcccambodia.com](http://www.fcccambodia.com)  
Phnom Penh's landmark restaurant has seven rooms with balconies offering views of the river. Each is individually designed and meticulously outfitted with

# Getting There



**BATTAMBANG**  
GST runs seven buses a day from the Central Market Bus Station to Battambang, starting at 6.45am and finishing at 12.30pm. The journey takes between five and six hours and costs US\$4. Far more comfortable and quicker (four hours) is a shared taxi. Expect to pay US\$40.

**KEP & KAMPOT**  
Both Kep and Kampot are served by the same bus service. Buses leave Phnom Penh at 7.30am and 1pm from the bus station 30 meters from the main entrance to the Olympic Stadium. Contact Hua Lian Transportation (Tel: 012 376 807) for details. Other buses leave from the bus station at the Central Market. A one-way ticket costs US\$5 and takes about 4.5 hours. Shared taxis can be found in the morning at the Central Market.

**KRATIE**  
Buses departing for Kratie leave from the Central Bus Station next to the Central Market. The seven-hour journey costs between US\$5 and US\$5.50 and buses leave at 7am, 7.30am and 9.30am.

**SIHANOUKVILLE**  
Mekong Express buses leave from their office close to the Green Vespa at 87A Sisowath Quay at 7:45am and 2.30pm, stopping at Orussey Market. Price is US\$5 including a snack and free pick-up. GST runs four buses a day (7:15am, 8:15am, 12:30pm & 1:30pm) for US\$4 from Central Market, but offer no pick-up or snack.

**HOTEL CARA**  
luxury you can afford

No.18, Street 47 & 84 Phnom Penh 023.430.066 [www.hotelcara.com](http://www.hotelcara.com)

high-speed Internet access and the latest mod cons.

#### Goldiana

10-12 Street 282, Tel: 023 219 558  
www.goldiana.com

Extremely popular hotel for visiting NGO workers presumably due to its close proximity to NGO-land and reasonable prices.

#### Kabiki

22 Street 264, Tel: 023 222 290  
www.thekabiki.com

Set in a secluded alley around the corner from the Pavilion, Kabiki is the first hotel in Cambodia dedicated to families and children. The two salt-water pools are designed with children in mind. The rooms have a double bed and a bunk bed as well as a small outside area for small children. Free WiFi, bar and restaurant.

#### The Quay

Sisowath Quay, Tel: 023 224 894  
www.chowcambodia.com

Five-storey, 16-room riverside boutique hotel has beautiful contemporary rooms designed by Gary Fell. The stand-out features are the roof-top jacuzzi and the very contemporary ground-floor bar and Chow Restaurant with WiFi.

#### The Pavilion

227 Street 19 Tel: 023 222 280  
www.pavilion-cambodia.com

Beautiful boutique hotel set in a colonial building with large, unique rooms, each with either a small balcony or garden. Outdoor swimming pool, free WiFi and a small poolside restaurant.

#### Villa Langka

14 Street 282, Tel: 012 449 857  
www.villalangka.com

Boutique hotel with restaurant and beautiful swimming pool, just a stone's throw away from Wat Lanka that has competitive rates and a good kitchen, although the pool tends to get over-run by children especially at the weekend.

### phnom penh - budget

#### Bodhi Tree

50 Street 113, Tel: 023 998 424

Small guest house with relaxed garden atmosphere and open balcony restaurant with an imaginative menu. Right opposite Tuol Sleng.

#### Cara Hotel

18 Street 47, Tel: 023 430 666

Just north of Wat Phnom, this stylish boutique hotel has well-fitted rooms at very reasonable rates and a great sushi restaurant.

#### L'Imprevu

Highway 1, 7km past Monivong Bridge  
Tel: 024 390 405

www.hotel-imprevu-resort.com  
Complex with twenty-four bungalows just outside of Phnom Penh. Tennis courts and excellent swimming pool make this a good break from the city.

#### Sokha Heng Guesthouse

29 Street 178, Tel: 023 990 077

Modern, clean 25-room guesthouse

located conveniently close to the National Museum. Has well-priced rooms with air-con and hot water.

#### Tonle Sap Guest House

4-6 Street 104, Tel: 023 986 722

www.tonlesapguesthouse.com  
Clean, well-kept guesthouse upstairs with 15 rooms, with air-con, fans, hot water, cable TV. Downstairs Pickled Parrot bar open 24 hours.

#### Velkommen Inn

23 Street 104 Tel: 092 177 710

Just off the riverfront, situated above Velkommen Inn Restaurant is the guesthouse of the same name. The spotless rooms have air-con, cable TV, minibar, safety box and en suite rooms with hot water. The hotel is located close to the bus stations and the ferry dock.

#### The Winking Frog

128 Sothea Blvd. Tel: 023 356 399

Central-located guesthouse with 31 en-suite, air-conditioned rooms. Downstairs is a British-run, 24-hour pub with sports bar, live music and good Thai food.

### sihanoukville

#### Cantina del Mar

Otres Beach, Tel: 012 702 502

Taco and seafood stall on one of Sihanoukville's most unspoilt beaches. Expect great Mexican food and some mean tequila cocktails. Open from 10am.

#### Holy Cow

Ekareach Street, Tel: 012 478 510

Beautiful restaurant set in a relaxing garden environment on the main street, with terracotta terrace downstairs and wooden dining area upstairs. Competitively-priced, good cuisine including vegetarian options. Open 9.30am to midnight.

#### House of Malibu

Serendipity Beach, Tel: 012 733 334

Clean bungalows fronting the beach with pleasant garden. Rooms come with air-con or fans and cable TV.

#### Independence Hotel

Independence Beach, Tel: 012 728 090

Beautifully restored hotel on Independence Beach, originally opened in 1963, reopened in 2007 following a complete refurbishment. Infinity pool and sweeping ocean views from most rooms. Gym, conference rooms and circular restaurant.

#### Le Vivier de 'La Pailote'

Victory Hill, Tel: 012 633 247

Upmarket French restaurant that outshines the other places on Sihanoukville's late night drinking street. Sophisticated French cuisine in a beautiful garden setting. Open for lunch and dinner.

#### Luna d'autunno

Ekareach Street, Tel: 034 934 280

Best Italian restaurant in Sihanoukville, serves a similar menu to the one in Phnom Penh, but with a heavier emphasis on seafood. Beautiful roof-top terrace and interior air-con restaurant. Open for lunch and dinner.

#### Mick & Craig's Sanctuary

Road to Serendipity Beach

Tel: 012 727 740

Open restaurant serving reliable food, including wood-fired oven pizzas. Bar has a big screen and pool table. The guesthouse has a few rooms, a bookshop and is a good source of travel information. Open 7am to late.

#### Oasis Hotel

Ekareach Street, Tel: 012 638 947

Spacious sports bar with large TV screen showing F1 and movies. Two pool tables often with plenty of willing female opponents. It also has spacious rooms ranging from. Open from 7am to late.

#### Otres Nautica

Otres Beach, Tel: 092 230 065

Boating company operating off Otres Beach. Has catamarans, lasers, sailing boats, sea kayaks as well as other vessels. Provides lessons and rental for beginner and expert sailors.

#### Reef Resort

Road to Serendipity Beach,

Tel: 012 315 338,

bookings@reefresort.com.kh

Small guesthouse set around a beautiful pool. Rooms have aircon, in-room safe and cable TV. Family rooms also available. Has a welcoming bar with excellent TV screen, slatte pool table and excellent Mexican cuisine.

#### Scuba Nation

Tel: 012 604 680 / 012 715 785

www.divecambodia.com

Five-star PADI centre offering daily trips to the area's many islands and reefs including the decent dive sites at Koh Rung Samloem and Koh Kon. Also run a range of PADI-certified courses. Has office in Phnom Penh.

#### Sea Breeze

Independence Beach, Tel: 034 934 205

Australian-run hotel with large air-con rooms opposite Independence Beach. BBQs include freshly caught fish and imported steaks. The bar has a 9-ball slatte pool table and a large screen for sporting events.

#### Snake House

Near Victory Monument, Tel: 012 673 805

So called because there is a house with snakes run by some Russians, rather than vice versa. If reptiles are not your scene, then the poolside bungalows and lush gardens provide a great spot to stay. The restaurant serves Russian and European cuisine and the bar can get very lively at night with dancing girls.

#### Sokha Beach Resort

Sokha Beach, Tel: 034 935 999

With its own private beach, excellent swimming pool and fine restaurants, Sokha is easily the most up-market place to stay in Sihanoukville. A live Filipino band plays around the cocktail bar at night.

#### Starfish Bakery Café

Behind Samadera Market Tel: 012 952 011

Excellent place for a healthy breakfast or lunch set in a relaxing garden environment

with good bread, salads, sandwiches, juices and porridge. Has a small shop run by the Rajana Association selling clothes and handicrafts. Good place to go for a massage. Open for breakfast and lunch.

#### Top Cat

Road to Serendipity Beach

Opposite the Reef Resort, this luxurious large screen movie house shows DVDs. The films are free but there is a charge for the air-con and comfortable couches.

### siem reap - bars

#### AHA

The Passage, Tel: 063 965 501

Sophisticated and beautifully designed wine bar selling a wide range of wines from around the world and tapas, as well as great cheese and Lavazza coffee. Open from 10.30am to 10.30pm.

#### Angkor What?

Pub Street, Tel: 012 490 755

"Promoting irresponsible drinking since 1998," this graffiti-laden bar is the mainstay of Pub Street. A healthy mix of loud rock, punk and grunge, buckets of vodka and red bull for US\$6 and a pool table ensures that you will never feel alone. Open from 6pm to late.

#### Chilli Si-dang

East River, Tel: 012 723 488

Restaurant bar serving Thai food and a wide range of wines, with a cool design, pool table and good sound system. Open from 9am to 11pm.

#### ELLA Wine & Jazz Bar

Trajan Pro, 300m west of hotel de la paix  
Tel: 092410 200

Set in an old Khmer house, with a large garden with platform beds, ELLA opened late 2008. It has an extensive wine list, international cocktails and tapas. The music is pure jazz and there is a separate wine room. Open Tuesday through Sunday 5pm to 1am.

#### Funky Munky

Pub Street, Tel: 011 481 303

The former riverside bar has moved to the corner of Pub Street. Good mix of music, excellent film posters and pool table compete with the pub grub for your attention. Try the Sunday lunch or build your own burger. Alternatively compete in the most competitive 'charity' quiz on a Thursday.

#### Giddy Gecko Bar

Lane off Pub Street, Tel: 092 857 400

Late night drinking den that has a good range of cocktails. Good option for those wanting to get away from the hordes on pub Street.

#### Laundry Bar

Old Market, Tel: 016 962 026

www.laundry-bar.com

Extremely chilled music bar just off Pub Street with great mellow decor and extremely cool t-shirts. Its multi-page music catalogue makes for the perfect respite from the Cambodian obsession with hip-hop, and they can burn 7 CDs. Free drink during the 6pm to 9pm washing hours. Open 6pm to late.

**Velkommen inn**

**Welcoming Bar & Restaurant**  
serving Western and Asian Food

Street 104 just off the river near the Post Office, Bus Stations & Boat Dock

**Pleasant Rooms Available**  
with A/C, Hot Water, Cable, Mini-Bar, Safety Box



#23 St. 104, Phnom Penh • Tel: 092 177 710 or 092 177 720  
Email: InnInPP@yahoo.com

**Italian Restaurant**  
**Luna d'autunno**  
Woodfired pizzaoven



68 Independence Str.  
Sihanoukville:  
Tel. 034 - 934 280  
Lunasihanouk@gmail.com

6c Street 29  
Phnom Penh  
Tel. 023 - 220 895  
lunaphnompenh@gmail.com

**Linga Bar**

*Alley behind Pub Street, Tel: 012 246 912  
www.lingabar.com*  
Laid back, gay-friendly bar with extremely chilled Buddha Bar tunes and some amazing light boxes. Unsurprisingly serves a great range of cocktails. Free WiFi. Open from 5pm to late.

**Miss Wong**

*Lane off Pub Street, Tel: 092 428 332*  
Imagine yourself in China at the turn of the last century and you won't go much wrong in Miss Wong. Extremely welcome addition to the same-old Siem Reap bar scene, serves excellent and original cocktails and dim sum. Open late.

**Molly Malone's**

*Pub Street Tel: 063 963 533  
www.mollymalonescambodia.com*  
Obligatory Irish Pub with lots of wood panelling and Irish memorabilia. The Guinness either comes in a cold can or alongside some steak in a pie. Also has a small guest house upstairs with air-conditioned rooms. Open from 7am to midnight.

**Red Piano**

*Pub Street, Tel: 063 964 730  
www.redpianocambodia.com*  
Bar set in a beautiful 100-year old colonial building that dominates one end of Pub Street. Lounge chairs spill out onto the street and the upstairs restaurant has great views of the mélé down below. Open from 7am to 11.30pm.

**The Warehouse**

*Old Market, Tel: 063 965 204*  
Popular expat bar opposite the old market that plays great 80s music. Good Asian fusion cuisine and with an additional selection of menus from nearby outlets, this is a great place to hide from the hordes along Pub Street and use the free Wi-Fi. Also has a small gallery upstairs. Open from 10am to 3am.

**X Bar**

*Sivatha Street & Pub Street,  
Tel: 092 207 842*  
Definitely the last option for continuing the night - just one for the road. Open from 4pm to very late. Supersize TV screen, table football and pool tables provide a number of options for staying up later.

**siem reap - cafés****Blue Pumpkin**

*Old Market, Tel: 012 946 227  
www.tbumpkin.com*  
Popular café with a great range of freshly baked breads and pastries. Serves shakes and health drinks for US\$1.75 and Bon Café coffee. Free WiFi. Also has outlets at Angkor Wat and the airport.

**Café de la Paix**

*Sivutha Bld, Tel: 063 966 000  
www.hoteldelapaixangkor.com*  
Like the adjoining Hotel de la Paix, this small café exudes contemporary chic. Excellent Lavazza coffee, bagels, salads and free Wi-Fi dished up in air-con surroundings. The sandwiches, salads and patisseries are all 50% off after 8pm.

**siem reap - galleries****Alliance Café**

*7 Makara Street, Wat Damnak Area  
Tel: 017 809 010*  
Small gallery established by Olivier Muzard adjoining his beautiful French restaurant features sculptures and paintings by Cambodian and international artists.

**Arts Lounge**

*Hotel de la Paix, Sivutha Boulevard  
Tel: 063 966 000*  
Large space in the ground floor of the hotel that showcases the works of Cambodian and international artists. All pieces focus on Cambodian subjects.

**Friends Centre**

*Achamean Street, next to the Angkor Children's Hospital,  
Tel: 063 963 409 (x7015)*  
International photography gallery curated by Brenda Edelson set in the Friends Centre. All proceeds go to the Angkor Children's Hospital.

**Happy Painting**

*FCC, Old Market, Domestic Airport  
Tel: 012 623 945, www.happypainting.net*  
Three shops selling the extremely colourful and positive work of iconic artist Stef. Accepts credit cards. Open 5.30am to 11pm.

**Klick**

*Alley behind Pub Street, Tel: 063 761 084*  
Commercial fine art gallery dedicated to the work of Swiss photographer Pier Poretti. Black and white photographs are given a face-lift using hand-tinted water colours.

**McDermott Gallery I & II**

*FCC Complex, Pokambor Avenue,  
Tel: 012 274 274*  
*Alley behind Pub Street, Tel: 092 668 181  
www.mcdermottgallery.com*  
Two galleries devoted to photographic works. The main gallery has a semi-permanent exhibition of the mesmerising photographs of Angkor taken by John McDermott and Kenro Izu. Second gallery features ongoing exhibitions of other other photographers. Open 10am to 10pm.

**The One Gallery**

*The Passage, Old Market Area  
Tel: 015 378 088*  
*Open 11am - midnight*  
Eclectic, contemporary gallery that combines Loven Ramos' mixed media artwork and objects and jewellery accumulated through his travels, with Don Protasio's fashion and accessories.

**The Red Gallery**

*FCC, Pokambor Ave., Tel: 092 822 323*  
A contemporary art space representing a select group of artists based in Cambodia. The Gallery exhibits sculptures, oil paintings, photography and mixed media. Hours: 10am to 10pm.

**The Wa Gallery**

*333 Sivutha Boulevard, Tel: 016 746 701*  
Gallery that mixes original artwork, handcrafted items, high design fashion by Siem Reap-based designer Eric Raisina, and other unique objects into a multifaceted mélange. Open 10am - midnight

online

**HELICOPTERS CAMBODIA**

We are a trusted provider of tourist and general charter flights through out the Kingdom of Cambodia. We also have extensive experience in flights supporting the oil and mining industries, fire fighting and construction.

**Phnom Penh (Head Office):**

+855 (0) 23 213 706

+855 (0) 12 735 216

**Siem Reap:**

+855 (0)12 814 500

Email: [helicopter.cam@online.com.kh](mailto:helicopter.cam@online.com.kh)[www.helicopterscambodia.com](http://www.helicopterscambodia.com)

**Happy Painting  
Gallery**  
Since 1995

Featuring the iconic artist  
**STEF**  
SURFPEREUN

- FCC- Phnom Penh 023-221-732
- FCC-Angkor 063-965-623
- Psar Chaas Quarter 063-963-114
- Domestic Airport 023-890-224

[www.happypainting.net](http://www.happypainting.net)



Helicopters Cambodia a wholly owned subsidiary of Helicopters (NZ) Ltd Group



## the blue pumpkin

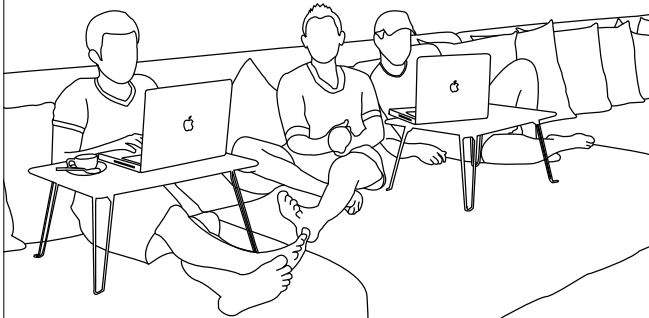

**bakery  
ice cream  
restaurant  
lounge**

free old market - siem reap  
wifi tbpumpkin.com  
spot 063 963 574  
open 06:00 to 22:00



## Cambodia Uncovered Exclusive Tours

**Do you live in Phnom Penh  
but feel you don't know  
Cambodia?**

**Do you have friends and  
family visiting but you  
have to work?**

We offer a genuine Khmer experience...  
village and cultural tours – in and around  
Phnom Penh.

- Cruise the Mekhong – day trips or longer
- Road trips – in & around Phnom Penh.... Kandal, Takeo, Kep – 1, 2 or 3 day trips
- Khmer cooking classes
- Boutique Accommodation

**I-4 persons only**

Phone: **012507097** or **012626353**  
**info@cambodiauncovered.com**  
**www.cambodiauncovered.com**



### Wat Kandal Gallery

River Road, near Wat Kandal  
Tel: 092 521 801

Tucked away by the river, and nestled under rambling shade trees, the gallery/studio shows Jean-Pierre Obriot's tranquil contemporary paintings of monks and Buddha images, as well as his collection of antiques.

### siem reap - hotels

#### Amansara

Pokambor Avenue, Tel: 063 760 333  
www.amanresorts.com

The ultimate in Siem Riep's chic hotels. The limited number of rooms and high-walled perimeter make this the ideal refuge from the paparazzi for the global Angkor-bound jet set. You'll only be able to get a room if Mr & Mrs Smith are not on a flying visit.

#### Claremont Angkor

17 Phum Wat Bo, Tel: 063 966 898  
www.claremontangkor.com

New reasonably priced hotel with swimming pool, gym and large outside terrace area. Well-located just across the river, but within easy access of both temples and town.

#### FCC Angkor

Pokambor Avenue, Tel: 023 992 284  
www.fcccambodia.com

Boutique hotel with 31 contemporary Asian-designed rooms spread around the garden and swimming pool. Free WiFi for guests both in rooms and around the pool.

#### Golden Banana Boutique

Resort Tel: 012 654 638 or 012 885 366  
Villas and Suites surrounding a salt water pool. Wireless Internet, private outdoor bath and showers, bar and restaurant. Rooms Range from US\$55 to US\$80  
www.goldenbanana.info

#### Golden Orange

Off East River Road, Tel: 063 965 389  
Mini-hotel with good sized air-con rooms that tends to have customers when others are empty. Nice outside bar makes for a good place to sit and have a few beers.

#### Hotel de la Paix

Sivutha Boulevard, Tel: 063 966 000  
www.hoteldelapaixangkor.com

With stoneware bathtubs in the rooms, mini-iPods upon request, flexible reading flashlights above the decadently lavish beds and inset photographic galleries along all the corridors, de la Paix is simply a modern design classic. The Arts Lounge downstairs is a great place to chill and has free WiFi.

#### La Palmeraie

N6 Airport Road, Tel: 092 952 113  
www.lapalmeraiedangkor.com

Boutique hotel set in gardens with beautiful palm trees off the road to the airport. Separate villa with its own pool can be hired out on an exclusive basis. Four more villas share a second pool. Idyllic spot to get away from it all.

#### La Residence d'Angkor

River Road, Tel: 063 963 390  
www.residencedangkor.com

Boutique, low-rise resort located across the river from the centre of town. Stylish wooden décor. Good pool and lush garden setting. Both upstairs Martini Lounge and downstairs bar have recently been revamped. Great place to splash out.

#### Raffles Grand Hotel D'Angkor

1 Charles de Gaulle, Tel: 063 963 888  
Elegant hotel with opulent gardens and a spectacular swimming pool in its grounds. Has frequent art exhibitions and Apsara dancing on nearby terrace.

#### Sokha Angkor

Cnr Sivutha Rd and National Rd 6  
Tel: 063 969 999, www.sokhahotels.com

Huge 5-star resort, sister property to Sihanoukville's Sokha Beach Resort. Located just back from the centre of town, it has a large pool, Irish pub and Japanese restaurant.

#### Tara Angkor Hotel

Road to Angkor, Tel: 063 966 661  
Elegant, boutique hotel with attractive swimming pool and rooms at competitive rates.

### Victoria Angkor

Near Royal Gardens, Tel: 063 760 428  
www.victoriahotels.asia  
Beautiful hotel with the most luxurious swimming pool and garden. Worth popping in and paying a visit if just to see the Siamese crocodiles in reception.

### siem reap - leisure

#### Body Tune

293-296 Pokambor Avenue  
www.bodytune.co.th  
Heavy grey stone Thai-run spa with selection of massages and facials. All masseuses work with Thai instructors.

#### Frangipani

Alley behind Pub Street,  
615-617 Hup Guan Street  
Tel: 063 964 391

Relaxing three-room beauty spa in the heart of town that's popular with expats. Now has a second outlet in the modern complex close to the Central Market. Frequented by those expats in the know.

#### Helicopters Cambodia

658 Hup Quan Street, Tel: 063 963 316

Professionally run company that has flights over the temples and beyond in modern, safe helicopters.

#### Phokeethra Country Club

Sofitel Royal Angkor Resort & Spa,  
Vithe Charles de Gaulle,  
Tel: 056 396 4600,

golf@sofitel-royal-angkor.com  
International standard 18-hole, 72-par golf course managed by the Sofitel Royal Angkor Golf and Spa Resort. Situated 16km outside of Siem Reap.

#### Sokha Helicopters

24 Sivatha Road Siem Reap,  
Tel: 012 184 8891,

www.sokhahelicopters.com  
Company flies modern French-built helicopters out of Phnom Penh and over Angkor. Licensed to fly helicopters anywhere in Cambodia.

### siem reap - restaurants

#### AHA

The Passage, Tel: 063 965 501  
Sophisticated and beautifully designed wine bar selling wide range of wines from around the world, tapas, great cheese & Lavazza coffee. Open form 10.30am to 10.30pm.

#### Alliance Café

7 Makara Street, Wat Damnak Area  
Tel: 017 809 010

French restaurant established by Olivier Muzard in a beautiful building just across the river. Has an adjoining exhibition space featuring sculptures and paintings by Cambodian and international artists. Also runs cookery lessons.

#### Burgers Without Borders

The Passage, Old Market, Tel: 012 482 764

Specialty burger bar, with good burgers made from Brazilian beef and soy shakes. The burgers are between US\$3.75 to US\$4.75 and the shakes are US\$2.75.

#### Butterflies Garden Restaurant

535 Wat Bo Road, Tel: 063 761 211  
www.butterfliesofangkor.com

Garden restaurant with large netting to keep the infinite number of butterflies within the grounds. Beautiful, relaxing setting and good clean food, but slightly more expensive than the main drag. Small gift shop also on the premises.

#### Chez Ninie

Lane off Pub Street, Tel: 012 582 782

Located conveniently right next to Miss Wong, this delightful small French restaurant has home-cooked cuisine with daily changing specials.

#### FCC Angkor

FCC Complex, Pokambor Avenue  
Tel: 063 760 280

The best example of contemporary Asian architecture in Cambodia, elegant bar & restaurant serve mix of Asian and international cuisine. The complex includes shops, the McDermott Gallery, Visaya Spa, a boutique hotel & arguably the coolest pool room in Cambodia.

#### La Noria

Wat Bo Road, Tel: 063 964 242  
Beautiful restaurant, set on a raised terrace area surrounded by trees. Serves good inter-



national and Khmer cuisine. Has traditional shadow puppet, musical and dance performances on Wednesdays. Open 6am to 10pm.

**Le Bistrot de Paris**

*Old Market Area, Tel: 092 964 790*  
Parisian-style bistro which opened in December 2006. Heavy wood-panelled interior with solid bar and aircon provide this restaurant with authenticity. Serves foie gras, croque monsieur, cheese, cold cuts and French wines.

**L'Oasi**

*East River Road, Tel: 092 418 917*  
The best Italian restaurant in, or rather just outside of, town. The hardest part is to find this place - keep on going on the East River Road in the direction of the temples, for a couple of kilometres until you see the large Italian flag, but once there the combination of the beautiful garden and home-cooked Italian pasta and pizza makes the trip worth it.

**Madame Butterfly**

*Airport Road, Tel: 016 909 607*  
Large restaurant set in a traditional wooden house with beautiful Chinese artifacts set in a pleasant garden. Serves Thai, French and Khmer cuisine.

**Maharajah**

*Next to Pub Street, Tel: 092 506 622*  
Halal restaurant offering 261 Royal Indian dishes, including a large selection of vegetarian and non-vegetarian specialties. Open from 10am to 11pm with free home delivery.

**Meric**

*Hotel de la Paix, Sivutha Boulevard  
Tel: 063 966 000*

*www.hoteldelapaixangkor.com*  
Elegant, contemporary restaurant with classically simple yet powerful black and white décor and an open kitchen. Executive Chef Johannes Riviere has devised a daily-changing seven-course traditional Khmer set menu. Try to book one of the swings outside on the terrace.

**Singing Tree Café**

*Wat Bo Road, Siem Reap, Tel: 012 490 265*  
Vegetarian alternative lifestyle garden restaurant with clusters of foliage surrounding wicker and bamboo seating. Menu includes veggie burgers, quiche, salads, sandwiches and tofu-based Khmer specialties. Also a centre for yoga, meditation and reiki healing.

**Tigre de Papier**

*Pub Street, Siem Reap, Tel: 012 265 811*  
The thing that differentiates this place from all the other restaurants along Pub Street is its half-day cookery classes, starting at 9am. Friendly, helpful French management.

**Viroth's**

*Wat Bo Road, Tel: 012 826 346*  
Elegant restaurant on the other side of river with excellent terrace garden. A good place to try royal Khmer cuisine including amok and beef Lok lak.

**siem reap - shops**

**Boom Boom Room**

*Old Market*  
Boasts a 176-page catalogue of tracks that can be burned either onto CDs or

mp3 discs. Also sells its designer t-shirts and hoodies as well as the Zico fashion label for women. Same chain as in Phnom Penh and Sihanoukville.

**Carnets d'Asie**

*333 Sivutha Boulevard, Tel: 016 746 701*  
Set in an arcade, this gallery-cum-bookshop has an extensive selection of photographs and books on Cambodia, including some black and white prints from the early 20th Century.

**Eric Raisina**

*53 Veal Village, Siem Reap  
Tel: 012 965 207 / 063 963 207*  
Accessories, home decorations, textiles and clothing created by Madagascar-born and French-trained designer. His amazingly vibrant designs have collected quite a following throughout the fashion world.

**Happy Painting**

*FCC, Old Market, Domestic Airport  
Tel: 012 623 945  
www.happypainting.net*  
Three shops selling the extremely colourful and positive paintings sculptures t-shirts and prints by iconic French-Cambodian artist Stef. Accepts credit cards.

**Jasmine Boutique**

*FCC Angkor, Pokambor Avenue  
Tel: 063 760 610*  
Same sophisticated, stylish boutique as on St. 240 in Phnom Penh. The perfect place for the ballgown you forgot to bring with you.

**U-Care Pharmacy**

*Next to Old Market, Tel: 063 965 396*  
Reliable western-style pharmacist and drugstore that also has two branches in Phnom Penh. Sells health and beauty products. Open 8am to 12am.

**travel**

**Cambodia Uncovered**

*Tel: 012 507 097  
www.cambodiauncovered.com*  
Offers village and cultural tours in Phnom Penh and surrounds including road trips, Mekong cruises, accommodation, cooking classes and other activities.

**Exotissimo Travel**

*46 Norodom Blvd, Tel: 023 219 151  
www.exotissimo.com*  
Excellent French-owned agency specialising in flight bookings, package holidays and a range of well-run tours of South-East Asia. Specialises in adventure tourism in Cambodia. Brochures are available online.

**Helicopters Cambodia**

*658 Hup Quan Street, Tel: 063 963 316*  
Professionally run company that has flights over the temples and beyond in modern, safe helicopters.

**Sokha Helicopters**

*2 St. 134 Phnom Penh, Tel: 023 885 773  
24 Sivutha Road Siem Reap,  
Tel: 012 184 8891  
www.sokhahelicopters.com*  
Company flies modern French-built helicopters out of Phnom Penh and over Angkor. Licensed to fly helicopters anywhere in Cambodia.



**សណ្ឋាគារ ខ្សាច់រំងាប់ កំពង់**  
**GOLDEN ORANGE HOTEL**

Group 1, House No 7, Slokram Village, Siem Reap  
Tel: 063 965 389 • www.goldenorangehotel.com  
reservations@goldenorangehotel.com

Rooms from \$30 (including breakfast), Free Broadband Internet / Wifi,  
Rooms have air-con, in-room security box, mini-bar, private shower  
with hot water, Deluxe rooms with jacuzzi, Cozy bar,  
Roof top terrace area. 10 minutes from the airport.



# Sihanoukville



**Travel Indochina**  
 43-44EO Street 108, Tel: 023 991 978  
[www.travelindochina.com.au](http://www.travelindochina.com.au)  
 Australian-owned and managed travel company specialising in small group journeys around Asia. Can also tailor trips for individuals.

- 1) The Big Apple 2) Spruce
- 3) Maple Leaf 4) The Trail Of
- Harry The Lonesome Pine 5) Harry
- Palmer 6) Nightmare on Elm
- Street 7) Wind in the Willows
- 8) The Oaks 9) The Joshua
- Tree 10) Harriet Beecher-
- Stowe 11) Bonnie and Clyde
- 12) Amazon 13) Don King
- 14) Mississippi 15) Rhine-
- stones 16) Harris Tweed
- 17) Blue Danube 18) Christ
- the Redeemer 19) Congo
- 20) Avon 21) Advance Aus-
- tralia Fair 22) The Flinders
- Ranges 23) North Territory -
- 170km South East of Darwin
- 24) Van Diemen's Land
- Tasmania 25) Botany Bay
- 26) A frog 27) Kevin Rudd
- 28) Canberra 29) Lobster
- 30) Queensland, New South
- Wales, South Australia

## Pub Quiz Answers



## Reef Resort Sihanoukville

*Sihanoukville's premiere boutique hotel restaurant & bar*



Try our new **Mexican** menu

*Quesadillas - Sizzling Fajitas - Burritos - Taquitos - Tacos - Jalapeno Poppers - Wraps*

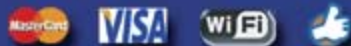

Serendipity Beach Road, Sihanoukville ☎ 012 315 338, 034 934 281

[www.reefresort.com.kh](http://www.reefresort.com.kh)

[bookings@reefresort.com.kh](mailto:bookings@reefresort.com.kh)

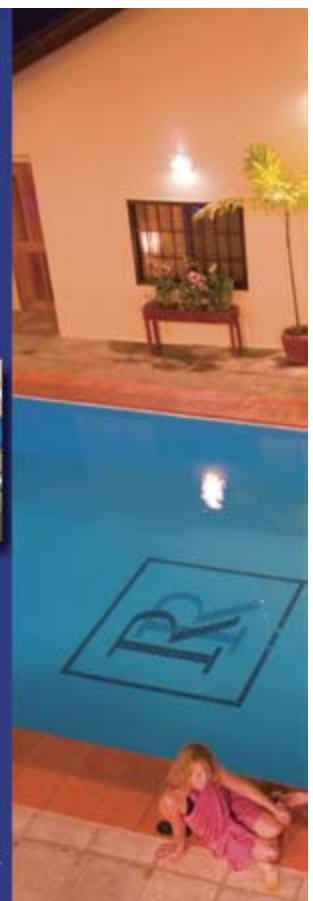

# unplugged

## Go East, Dear Boy

Faced with the impending collapse of the U.S. print media, **Will** looks towards Cambodia for salvation.

### I LOVE THE PACIFIC

Northwest. I wasn't born here, but I tend to think of it the way most Cambodians think of their home province. The states of Washington and Oregon have their own unique culture and mild climate – even if this part of the world is a little too obsessed with milked-down coffee and flannel.

After working as a copy editor for a few daily newspapers in the Northwest, I've always had a half-baked dream of working at one of the great titans of daily newspapers in the Northwest, Portland's *The Oregonian*, *The Seattle Times* or the *Seattle Post-Intelligencer*.

And then the Internet started killing the newspapers. On Jan. 9 the *Seattle Post-Intelligencer*, circulation 120,000, announced it would be sold in the next 60 days or cease publication.

Not only does that remove a daily newspaper from my list of dream jobs, it also means more than 100 experienced journalists will be on the market competing for a dwindling number of newspaper jobs. And most newspapers are reducing staff, not adding jobs.

Where are they going to go? I only have the advice I offer to every problem – go to Cambodia!

### REPORT ON THIS

Cambodia is poor, undeveloped and racked by tension. There's a story for every political perspective.

Love free trade? You can report on the rapid export- and tourism-driven economic growth Cambodia's enjoyed over the past decade.

Hate globalisation? There's lots of people working in sweatshops and local officials willing to blame foreigners for all their problems.

Think the United Nations is the bane of humanity or its only salvation? You can find anecdotes to back up either belief on the banks of the Mekong, the Sap and the Bassac.

Depending on how you look at it, Cambodia is either a success



or an example of everything that can go wrong in a country. And many of Cambodia's government officials, unlike in most countries, are only a phone call away. So long as you're a foreigner, there is a remarkable degree of freedom of speech compared to neighbouring countries.

And there are plenty of buyers. As America's newspapers and magazines shed their regular staffers, there are more opportunities for freelancers to sell their work. There are plenty of people who have started their own blogs about Cambodia or even their own print publications.

### TEACH WHAT YOU KNOW

If you can't find someone to buy your stories – I'm biased, but I think the publication you're holding in your hands is a great place

to start – you can always put down the reporter's notebook and pick up a marker pen.

There's no shortage of schools, colleges, universities and learning centres in Cambodia willing to hire a native English teacher. Some of them even pay. Having journalism experience might help you get in the door, though as they never bother to check references it doesn't really matter what you say, as long as you say it with a neutral American accent.

If you're not pressed for cash – the rarest journalist of all in my experience – there are many opportunities to volunteer as a teacher in Cambodia, which is what originally brought me there. Years later, I still fondly remember volunteering as emotionally and spiritually rewarding – but not financially rewarding.

### DEVELOP MINT

If you can't find a story, and you find the best part of teaching is making your students cry, there's always work with NGOs (non-government organisation – nobody in the U.S. seems to know that acronym while it's the first English many Cambodians learn). Even the smallest development organisations will need an occasional freelance editor or some public relations help.

And the best reason to head to Cambodia? Compared with the cool drizzle of Seattle, Cambodia will feel like the Garden of Eden – at least until the first monsoon hits.

*Will Koenig lives in Oregon and, as of press time, still works as a journalist. Contact him at will.koenig@gmail.com. Alternatively follow his letters from Oregon at: www.asialifeguide.com* 

## Challenge Nora: Unlicensed

According to chapter 1, article 4 of Cambodian traffic law (the un-official translation): “all vehicles, which are moving along the roads, MUST have drivers”. According to chapter 9, article 1, all drivers of vehicles must have valid driving licenses. And so, in what looks like a thinly disguised attempt by **AsiaLIFE** to transform me, yet again, into their local chauffeur, I go on the hunt for a Khmer driving license.

MY FIRST STOP IS A VERY popular driving school.

**Question:** “Do I need a driving license to drive in Cambodia?”

**Answer:** “Yes”

**Question:** “But I can drive a moto without one?”

**Answer:** “Yes”

**Question:** “So I don’t need a Khmer license to drive a moto?”

**Answer:** “Yes.”

**Question:** “But I need a license to drive here?”

**Answer:** “Yes”

Try making sense of that. Finally the woman behind the counter asks to have a look at my current license and tells me that to change my license into a Khmer one, I need three passport photos, a colour copy of my license, as well as copies of my passport and visa. Plus \$40 – the processing fee. The word ‘change’ worries me – I don’t want to change my good, trustworthy, uncorrupted Finnish license to a Khmer one (which I am not sure shares those admirable attributes), I simply want an additional Khmer license. Yes, the woman says. “Yes, no problem”.

Not convinced, I call up the Ministry of Transportation. They advise me to go to their office near the water park on the way to the airport. Completely devoid of signs, the place is a mission to find, but I’m finally pointed down a dirt path towards a few old low-rise buildings.

As I get off the moto a sea of men come at me shouting ‘License? License?’. Oddly enough it seems I’m not the first barang to make the trek down to this office. I nod for yes, but am uncomfortable with simply handing my existing license over to one of these ragged-looking men –



Ready to roll

the situation rather reminds of stories about dim-witted tourists handing everything over as soon as they step off the plane in a foreign country to some guy who claims he will help them through customs, they of course, never see their documents again. Deciding not to be a stupid tourist, I hold on to my card and head for the entrance.

Inside, there is a woman preparing lunch among empty office desks, filing cabinets and dust. She points me to the room next door where a well-dressed woman asks me to take a seat whilst chattering away on her pink mobile phone. ‘Can I help you?’ she gesticulates. ‘I want a Khmer license’ I declare. She doesn’t understand. Good start.

Eventually she takes a look at my Finnish license, then looks at me, stops for a moment to consider, and says it - “\$35”. That’s less than at the driving school, but as it is Cambodia I feel the need to haggle – “Can it be less?”; she looks at me with such confusion that it becomes brilliantly clear to me that it cannot be less, but that it probably could be more if I don’t shut it.

I give them my photos and copies, sign a paper or two, give them my address, and some 20 minutes later it’s done. Quick and easy. I will now have my very own Khmer license – in four weeks time. “Maybe it can be faster...?” I suggest. Again, the woman looks at me like I’m

an idiot and shakes her head – of course it can’t be faster. At least not without another \$20 I suspect.

One month later I make the trek back to the office. The same sea of men engulf me and I start to wonder what it is they really are offering – would it have been cheaper to go through them? Maybe faster? Why are they here, right in front of the office? Who are they? Alas I will never know. As I, receipt in hand, step in to the office and claim my brand new Khmer driving license.

The traffic law states all moving vehicles must have drivers – I wonder if there is an article according to which all drivers must have vehicles? At least now I can legally drive one. **■**

# This Month in History

celebrations, astronomy, capone, wall street



## ■ NATIONAL HOLIDAY, BUT KEEP IT QUIET... 🚩

February 11

On this day Japanese celebrate the founding of the nation and the imperial line by its legendary first emperor Jimmu, who accessed the throne in 660 BC. In its original incarnation, the holiday was named Empire Day (Kigensetsu) and was supported by those who believed that focusing national attention on the emperor would serve a unifying purpose. With large parades and festivals, in its time, Kigensetsu was considered one of the four major holidays of Japan. Given its reliance on Shinto mythology and its reinforcement of the Japanese nobility, Kigensetsu was abolished following World War II. The commemorative holiday was re-established as National Foundation Day in 1966. In contrast with the events associated with earlier Kigensetsu, celebrations for National Foundation Day are now relatively muted. Customs include the raising of Japanese flags and reflection on the meaning of Japanese citizenship. The holiday is still relatively controversial however, and very overt expressions of nationalism or even patriotism are rare.

## ■ IT'S THE SUN, STUPID!

February 19, 1473

Astronomer Nicolaus Copernicus (1473-1543) was born in Torun, Poland. Considered the founder of modern astronomy, he theorized that the sun, not the earth, was the centre of the solar system. Although Greek, Indian and Muslim savants had published heliocentric hypotheses centuries before Copernicus, his publication of a scientific theory of heliocentrism, demonstrating that the motions of celestial objects can be explained without putting the Earth at rest in the centre of the universe, stimulated further scientific investigations and became a landmark in the history of modern science that is known as the Copernican Revolution. Among the great polymaths of the Renaissance, Copernicus was a mathematician, astronomer, physician, classical scholar, translator, artist, Catholic cleric, jurist, governor, military leader, diplomat and economist. Among his many responsibilities, astronomy figured as little more than an avocation — yet it was in that field that he made his mark upon the world.

## ■ NOBODY SHOT ME

February 14, 1929

The St. Valentine's Day massacre occurred in Chicago as seven members of the Irish Bugs Moran gang were gunned down by five of the Italian Al Capone's mobsters posing as police. When one of the dying men, Frank Gusenberg, was asked who shot him, he replied, "I'm not gonna talk - nobody shot me." The slaughter exceeded anything yet seen in the US at that time. The actual bricks used to build the north inside wall of the building where the mobsters were lined up and shot were claimed to be responsible for bringing financial ruin, illness, bad luck and death to

anyone who bought them. In 1967 they were purchased by Canadian businessman George Patey. In 1978, Time Magazine reported that Patey reassembled the wall and put it on display in a wax museum with gun-wielding gangsters shooting each other in front of it to the accompaniment of recorded bangs. The wax museum later went bankrupt.

## ■ FIVE SQUARE INCHES PLEASE, TO TAKE AWAY 📏

February 1, 1926

Land at Broadway and Wall Street sold at a record US\$7 per square inch. Three years later, 1929 brought the "Great Crash" of the stock market, ushering in the Great Depression. As a figure

of speech contrasted to "Main Street", the term "Wall Street" can refer to big business interests against those of small businesses and the working or middle class. "Wall Street" is commonly used interchangeably with the phrase "Corporate America" and became one of the key themes during the recent U.S. presidential election campaigns. Wall Street, more than anything, represents financial and economic power and often conjures up ideas of elitism, power politics and cut-throat capitalism, but to Americans it also stirs feelings of pride about the market economy...until recently. Panic is now the word of the hour on Wall Street with some drawing comparisons with the Great Depression of the 30's. 📉



## ■ CELEBRITY BIRTHDAYS THIS MONTH

Figures in brackets represent the age they will be on their birthday.

Feb. 1 – Lisa Marie Presley & Pauly Shore (Both 41); Feb. 2 – Farrah Fawcett (62); Feb. 4 – Alice Cooper (61); Feb. 5 – Jennifer Jason Leigh (47); Feb. 6 – Rip Torn (78), Zsa Zsa Gabor (90); Feb. 7 – Ashton Kutcher (31), Chris Rock (44); Feb. 8 – Seth Green (35), Gary Coleman (41), Nick Nolte (68); Feb. 9 – Mena Suvari (24), Mia Farrow (64), Joe Pesci (66); Feb. 11 – Jennifer Aniston (40), Sheryl Crow (46), Burt Reynolds (73); Feb. 12 – Christina Ricci (29), Arsenio Hall (54), Judy Blume (71); Feb. 13 – Robbie Williams (35); Feb. 15 – Matt Groening (55); Feb. 16 – Ice-T (51); Feb. 17 – Paris Hilton (28), Michael Jordan (46); Feb. 18 – Molly Ringwald (41), Dr. Dre (44), Matt Dillon (45), John Travolta (55), Cybill Shepard (59), Yoko Ono (76); Feb. 20 – Cindy Crawford (43), Sidney Poitier (82); Feb. 24 – Steven Jobs (54); Feb. 25 – George Harrison (66); Feb. 26 – Mitch Ryder (64), Erykah Badu (37)

# February Horoscope

your month ahead according to the stars

## ■ AQUARIUS (JAN. 21 – FEB. 19)

Happy Birthday Aquarius! February is a banner month for your personal interests, energy, charm, and initiative. Despite some blockages around the 5th, when the past comes back to haunt you, the month brings pleasant energy and fun surprises. Few Aquarians will end the month without having changed some aspect of their personal appearance, manner, or style. A partner or relationship matter demands your attention around the second Monday of the month. The need to strike a balance between your own needs and those of another becomes clear. It's time to compromise and negotiate.

## ■ PISCES (FEB. 20 – MAR. 20)

Taking time out to research, reflect, and develop your inner resources figures strongly this month, Pisces. Much of your energy is channelled into private matters. Around the 9th, there could be changes necessary in your job or health routines. You can use this surge of emotional energy to make positive changes to your routines. Do something to improve your work conditions if they are annoying you. Get going on your exercise or nutrition program that you know you need to do in order to feel more balanced and healthy.

## ■ ARIES (MAR. 21 – APR. 20)

You are pouring a lot of energy into generating business income, building your dreams, and planting the seeds for ideas this month, Aries. Others are taking up a lot of your time as well, whether they are friends, members of a group, or simply part of your own community efforts. Your social agenda is hopping! You are more impartial than usual, and you can use this easy energy to enhance friendships. After the full moon, romantic relationships require considerable attention, especially since the demands of your larger goals in life have been eclipsing your pleasure-seeking activities.

## ■ TAURUS (APR. 21 – MAY 21)

Career and professional matters become a top priority in February, Taurus. While career is at the forefront of your mind, your instinct is to retreat from the hustle and bustle. Relationships are practical more than emotional. Events around the full moon call your attention to domestic matters. House repairs, family dramas, and other such issues, crop up now. Striking a balance between energy spent on work and energy put into domestic matters is essential now. Balanced attention to your public and personal lives is what you need to focus on. It's time to prioritize.

## ■ GEMINI (MAY 22 – JUN. 21)

The urge for more from life than what you get from everyday mundane activities is strong, Gemini. You want to broaden your horizons in any way that leads you into unexplored territory, whether this is intellectual or physical (or both). Anything less will leave you feeling unsatisfied and restless. Events around the 9th call your attention to communications, schooling, means of transportation, mobility, neighbours, or siblings. Whether or not you want to, you need to run errands and take care of paperwork, or you won't be able to satisfy your yen for adventure!

## ■ CANCER (JUN. 22 – JUL. 22)

This month, you are pulling back a little, strategizing, observing, and researching your options, Cancer. While work and other public matters are not making headlines for you in February, your personal life is certainly heating up. You take little interest in anything (or anyone) superficial now, and you are a true student of human nature. Taxes and debts are likely a preoccupation. Events and circumstances around the lunar eclipse on the 9th necessitate a change in your spending habits and budget. You are receiving a

“cosmic push” to make necessary financial changes in your life.

## ■ LEO (JUL. 23 – AUG. 22)

Leo, much of your attention is drawn to improving your close relationships in February. It's best to give the stage to others now, and to put your personal projects on the back burner just for now. A Lunar Eclipse occurs in your sign on the 9th, giving you a cosmic push to change your image or redefine your personality. Finding a balance between autonomy and dependence is what this eclipse is about. Your emotions are on your sleeve right now, and whether you can succeed as a leader is “tested” right now.

## ■ VIRGO (AUG. 23 – SEP. 23)

Any suspicions that you are a workaholic will probably be confirmed this month, Virgo! You are making a dent in your “to do” list. You might notice aches and pains a little more now, as you do all the little things that don't seem to be working “just right”. Naturally, there will be a point when you recognize an overwhelming need for rest and spiritual renewal. You've been deeply involved in your work and routines. It's time to balance your life with some down time--otherwise, you simply won't feel whole.

## ■ LIBRA (SEP. 24 – OCT. 23)

A truly fun month is in store for you, Libra. In 2009, you are discovering (and re-discovering) all the things that bring joy to your life and February is a good example of this playful energy. Entertaining, recreation, romance, children, and hobbies—all of these things appeal more than ever. Your charm soars, and your romantic life picks up pace. Around the time of the Lunar Eclipse on the 9th, a friend may need your assistance. Responsibilities to others become very clear. Domestic matters move forward after a lull.

## ■ SCORPIO (OCT. 24 – NOV. 22)

The year 2009 brings much contentment on the home front for you, Scorpio, but that doesn't mean you won't be busy in this area of life! In fact, this month, activities in and around your home and involving family occupy much of your time. Events and circumstances occurring in the second week of the month give you a cosmic push to handle professional matters, and to review or change your career goals. On a moment's notice, you are called to perform. It's best to keep your cool and do whatever you can to show your competence.

## ■ SAGITTARIUS (NOV. 23 – DEC. 21)

You can't seem to sit still this month, dear Sagittarius! With all that's going on around you, be careful not to let the little things cloud your perspective of the bigger picture. Great conversations, happy news, and plenty to learn—these are the themes of February. Information overload could be an issue, if you let it become one. With all of the attention you've been giving to mundane affairs, you could be wondering when you're going to have some fun. You want to take a leap of faith now, particularly around the 9th.

## ■ CAPRICORN (DEC. 22 – JAN. 20)

This month, Capricorn, you are busy building your resources, buying new things that have long-term “shelf life”, and thinking up ideas about how to make more money. Financial matters are in focus. Sensual pleasures appeal more than usual. Around the 12th, some drama with regards to a spouse's income, or your taxes and investments, may occur. It could be time to settle some of your debts, financial or otherwise. What makes you feel comfortable and secure needs to be balanced with your attention to other people's needs and comfort levels. ■

# Best Kept Secret: Mandy Fu Nails



THERE ARE THOSE WHO dismiss nail art as simply too girly and far too kitsch to engage with. Once you've taken the plunge into this delicate world of flowers and sparkle, however, it is difficult to stop craving beautifully adorned nails, and of course only the best is good enough.

One of the very finest places in town for professionally painted nails is Mandy Fu's on the first floor of Paragon Mall. It's slightly more expensive than its counter-parts at other malls, but the skill with which the girls here doll up your fingers is way beyond anywhere else making it worth those extra few dollars.

A set of 10 pimped up fake nails will set you back a mere US\$2.50. However, if you intend to use your hands in the near future it is perhaps advisable to go for flowers and sparkles painted directly onto your own nails.

There are hundreds of models to choose from, though the size of your nails will determine which ones will actually fit. Unless you like the long local style toenails, it's best to opt for a coat of paint and some sparkle on your tootsies. You can be more inventive with your fingernails, though here too the artist is likely to bemoan their lack of length. Note that unless specifically asked for, you don't get a full manicure or pedicure.

## BRUSH ACTION

Once you've chosen the pattern as well as the colour, the girls make a start on your hands and feet simultaneously. Once your nails are cleaned and filed into shape out comes the first coat of clear polish, followed by your chosen colour. Then the artist gets to work.

Using a tiny millimetre thin brush, she dips one side of the tip in one colour and the other side in another. By subtly turning the brush on your nail, she paints the first flower petal. Repeated several times over, a flower appears. Leaves and other little bits and bobs follow. When finished, you can hardly believe the flower isn't just a sticker stuck on.

Ask for a bit of added glitter for that extra sparkle, wait for the finishing coat to dry, and you're set.

Sparkly toenails (without painted art) are yours for a mere US\$2, while expertly glammed up and adorned fingernails set you back US\$5. Pending what you do with your fingers, the polish lasts for 2-3 weeks.

Finally, if the sparkle bug has really got to you, Mandy Fu's also has 'diamonds' to ornament your teeth with. Popular with hip Khmer youth, a single diamond super-glued to your tooth is yours for a bargain 1000 riel.

**Mandy Fu Nails Beauty & Nails Care, 1st Floor, F11, Paragon Mall, street 214. Tel: 012 617 463. Open 9.30am-8pm**

[www.AsiaLIFEguide.com](http://www.AsiaLIFEguide.com)

PHNOM PENH  
**AsiaLIFE**guide

## Prosperity Chinese Dinner Menu with Live Seafood

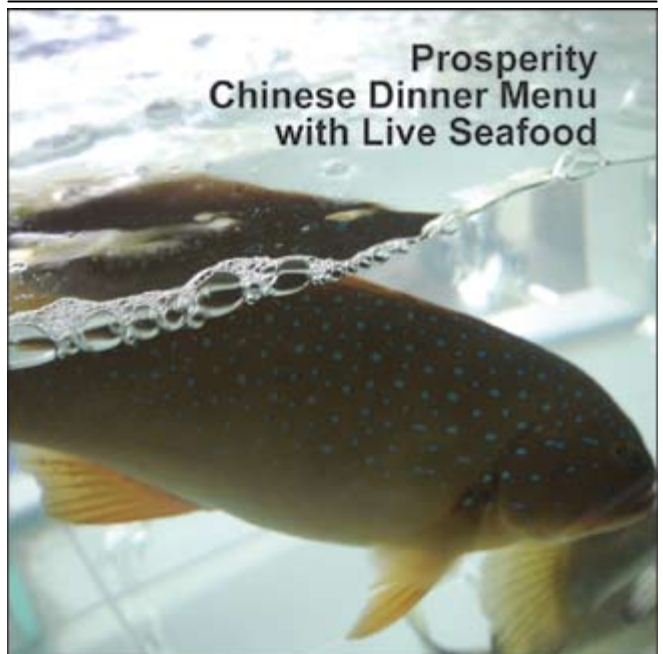

free Tsingtao Beer

GROUND FLOOR OF ALMOND HOTEL  
N° 128, SOTHEA'S BLDG. CORNER OF RUSSIAN EMBASSY  
P +855 23 22 08 22 F +855 23 22 07 22  
manager@almondhotel.com.kh



# Top Shelf Gentlemen

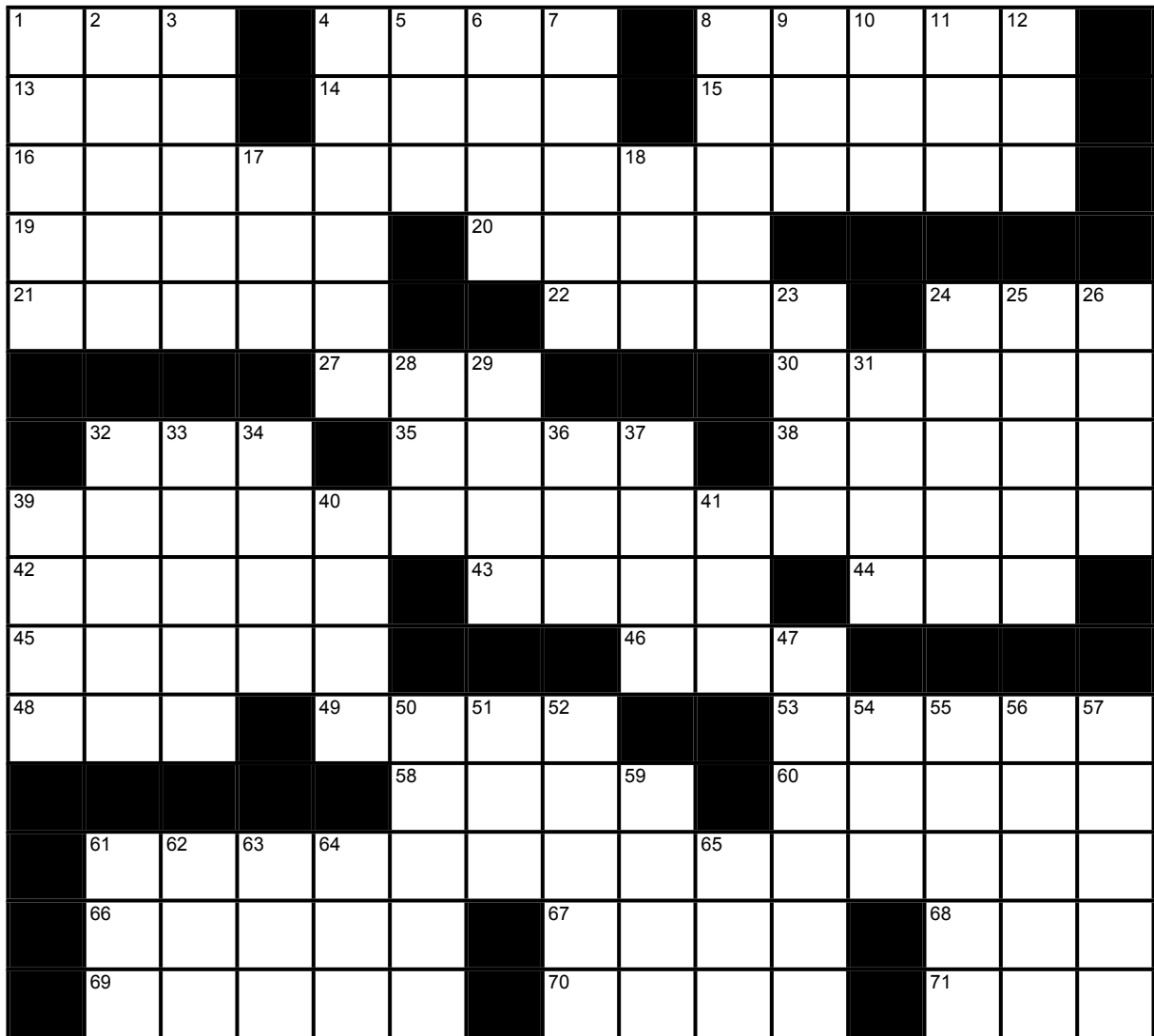

© David Flack 2008

## ACROSS

- 1 Really cool, short heater  
 4 Pig movie  
 8 Mammal with a chameleonic trait  
 13 Pub offering  
 14 Apple's saviour  
 15 Dabbling ducks  
 16 Inscription that could precede 1943 – 1971 in Pere Lachaise  
 19 Follows round  
 20 School for princes  
 21 Language spoken by over half a billion  
 22 Cancel an edit  
 24 Major centre  
 27 Toothed disc  
 30 Scan the horizon  
 32 Fathers  
 35 Oilman perhaps  
 38 Came up between 2 thorns  
 39 Multi-tasker?  
 42 Moving

- 43 Word with football or hole  
 44 GMT -7  
 45 Homo\_\_\_\_\_  
 46 Transport twisted arc  
 48 14 across' white buds  
 49 It's demanded in the name of love  
 53 Swiss mathematician Leonhard  
 58 Wading bird  
 60 Like a free-runner  
 61 OJ lawyer, now deceased  
 66 Skirt or frame type  
 67 Online shopping trolley  
 68 Didn't allow to go off  
 69 Doles (out)  
 70 Lessens  
 71 Replace a button

## DOWN

- 1 King who may speak 21 across  
 2 Witnessed excuse  
 3 The Devil's cohort

- 4 Consisting of living organisms  
 5 Mar follower  
 6 Be responsible for yawning  
 7 Chops  
 8 Mick or Keith  
 9 Card beaten by one from court  
 10 Or 45 across  
 11 The greatest proclaimer  
 12 Sml measuring device  
 17 Detractor's weapon, hoping some will stick  
 18 Drunkard  
 23 Ruler before a revolution  
 24 Anorak features  
 25 Cause of underdogs' celebration  
 26 "Event, E-V-E-N-T, event," events  
 28 Lout  
 29 Have (a bite or a seat)  
 31 Revision technique  
 32 Turkish title  
 33 Board treader

- 34 Outer layer  
 36 Entire  
 37 ASEAN, for one  
 39 Mock or mocking stunt  
 40 Metal sources  
 41 Doomed flight 800 operator  
 47 Takes action  
 50 Prongs  
 51 Jedi master  
 52 Concealed weapon  
 54 Typical barang reaction to prahok  
 55 Moneys of Italy and Turkey once  
 56 Not just cheer up  
 57 Begin again  
 59 Worker at a strike site  
 61 Preserve creators of Sound Effects  
 62 Bullring cheer for Gunnar  
 63 Assassination  
 64 Phnom Penh to Stung Treng dir  
 65 Eyeball 🍷



# Sudoku Answers



Gwan Ching Lee

We can't give you a puzzle without providing the answers. So here is the completed puzzle from this month's issue and the previous issue of AsiaLIFE.

3	7	6	2	9	1	8	4	5
5	9	1	4	7	8	2	6	3
2	4	8	5	6	3	1	9	7
1	8	9	6	3	7	4	5	2
4	5	3	8	2	9	7	1	6
6	2	7	1	4	5	9	3	8
9	6	2	3	8	4	5	7	1
7	3	5	9	1	2	6	8	4
8	1	4	7	5	6	3	2	9

ISSUE 26

5	4	6	1	7	3	8	2	9
7	9	8	4	2	5	3	1	6
2	3	1	8	6	9	5	4	7
1	5	4	9	3	6	7	8	2
6	8	2	7	5	4	9	3	1
9	7	3	2	1	8	6	5	4
3	2	5	6	4	7	1	9	8
4	6	9	5	8	1	2	7	3
8	1	7	3	9	2	4	6	5

ISSUE 25



## Say hello to the world and WIN!

Email your travel photos to [naomi@asialifeguide.com](mailto:naomi@asialifeguide.com) for a chance to win a Mystery Prize.

For a chance to win a hello SIM pack SMS to 015 650619 with your answer to where this month's photo was sent from.

- A. London
- B. Egypt
- C. Fu Chou

You always get more with hello

To enjoy calls for 25c/min to anywhere in the world:

166 + Country Code + Phone Number + ☎

E.g: To call Malaysia, +603 12345678, please dial 16660312345678

TMIC reserves the right to change product features without prior notice.

It all starts with hello

hello care: 1452 or 016 810 000 | [www.hello.com.kh](http://www.hello.com.kh)

# The QuizMaster

■ TREES

1. What nickname is given to the American city of New York?
2. Which six lettered word means to make neat, smart or trim?
3. What is the national symbol of Canada?
4. What was the title of the song that was a hit for Laurel and Hardy from the 1937 film 'Way Out West'?
5. Which spy character did Michael Caine play in the 1960's films 'The Ipcress File', 'Funeral in Berlin' and 'The Billion Dollar Brain'?
6. Still on the subject of films, which film featured the character called Freddie Kruger?
7. Ratty, Badger and Mole are all characters from which 1908 novel?
8. Which is the oldest of the English Classic Horse Races?
9. Which album entered the UK Charts at number 1 in March 1987 and became the fastest selling album in history?
10. Who wrote Uncle Tom's Cabin?

■ RIVERS

11. What were the first names of the bank robbers Parker and Barrow?
12. Which on-line trading organisation was originally called Cadabra?
13. What is the name of the American convicted murderer, noted for his trade mark hair-style boxing promotions?
14. The city of Jackson is the capital city of which US State?
15. What name is given to the fake diamonds which featured within the title of a 1975 hit for Glen Campbell?

16. Which specific hand woven woollen fabric are the Scottish islands of the Outer Hebrides famous for manufacturing?
17. Which piece of music by Johann Strauss is often thought of as the unofficial National Anthem of Austria?
18. What is the name of the statue which overlooks Rio de Janeiro?
19. The African city of Kinshasa is the capital of which country?
20. Which American company were the first to sell cosmetics door-to-door?

■ DOWN UNDER

21. Which song was written by Scottish born Peter McCormick in 1878?
22. Which mountain range is named after the first man known to have circumnavigated Australia?
23. Where is Kakadu National Park?
24. Which area of Australia was once named after a Governor-General of the Dutch East Indies?
25. James Cook originally called it Sting Ray Bay – but how is this area of Sydney better known?
26. What kind of animal is Tidalik in the Australian story?
27. Which famous Australian is also known as Lù Kèwén?
28. What is Australia's largest inland city?
29. What type of animal is a Moreton Bay Bug?
30. Which 3 states meet at Cameron's Corner?

■ ANSWERS ON PAGE 93

# Sudoku MIND GAMES TO KEEP YOU THINKING

Level: Difficult

Gwan Ching Lee's time: 20 mins

3	7			9	1			
						2	6	
		8	5					
	8				7			2
4				2		7	1	
6				4		9	3	
						5	7	
		5	9					
8	1			5	6			

■ ANSWERS ON PAGE 89

# Quote Unquote

■ CRUMBLING DOWN?

*This month we continue to build on your quotation library.*

*"A doctor can bury his mistakes but an architect can only advise his client to plant more vines."*

— Frank Lloyd Wright.

*"Ruins are the most persistent form of architecture."*

— Joseph Brodsky.

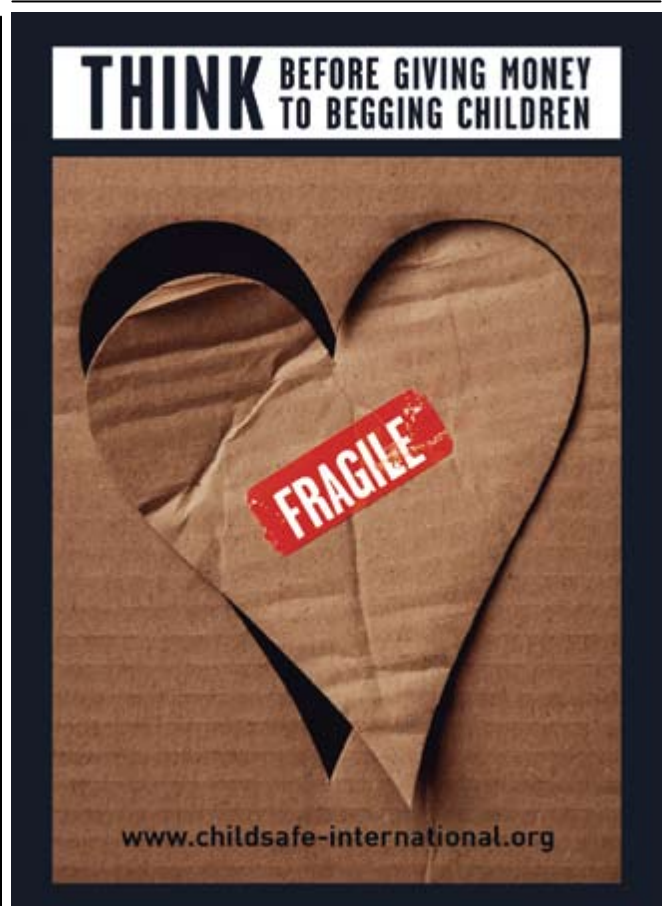

Celebrate *Love* this Valentine's Day with Star-Cell  
...and get



*Minutes Free  
every month*

*From 1st January 2009 when you buy Star-Cell 098 simcard  
you can get 300 minutes free every month, with 10 minutes  
credited to your balance daily*

*Please dial \*800\*01# to activate the Star 300 promotion*

# New Year Extravaganza



**THOUSANDS OF PRIZES TO BE WON  
AND ALL YOU HAVE TO DO IS TOP-UP!!!**

EVERYDAY - 1,500 bonus talk time winners. EVERY WEEK - 3 Nokia Slide Phones, a Sony Flat Screen LCD TV and a brand new Yamaha Fino to be given away. PLUS the 2009 Toyota VIGO 4WD for the grand prize winner.

The most exciting part is that all you have to do is to top-up and you automatically get a chance to win any of these exciting prizes up for grabs. Hurry the more you top-up the more chances of winning!

- Promo period is from December 22, 2008 to February 22, 2009  
Promo valid for top-ups of \$2 and more for both iLoad and Scratchcard.
- Daily winners will be notified via SMS
- Weekly winners will be announced on Cellcard Scene on CTN